

NOTES: UNLESS OTHERWISE SPECIFIED

1. SEE DRAWING NO. CB-00290 AND PROCEDURE P-1000 FOR ASSEMBLY AND TEST INSTRUCTION. PROCEDURES AND ASSEMBLY DRAWINGS ARE FOR INTERNAL USE ONLY.
2. ALL TESTING IS PERFORMED IAW BATTERY COUNCIL INTERNATIONAL STANDARDS.
3. ALL DIMENSIONS ARE INCH [MM].
4. ABBREVIATION USED IN TITLE IS: SEALED LEAD ACID (SLA).

REVISIONS			
REV	DESCRIPTION	DATE	APPROVED
A	SEE DCN PVX1080TA	8/10/11	JBT
B	REVISED NOTE 1	8/29/16	PH

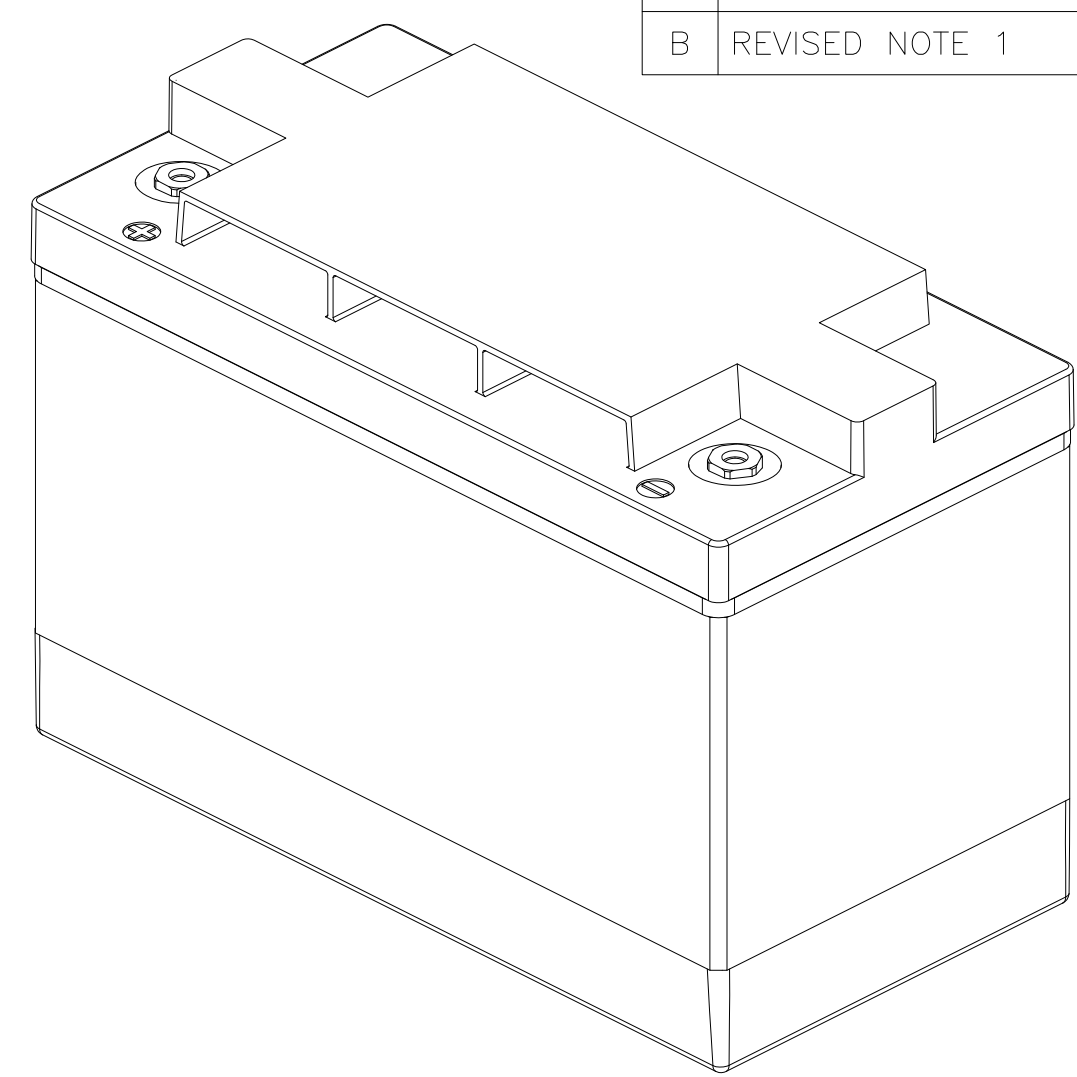

REFERENCE VIEW

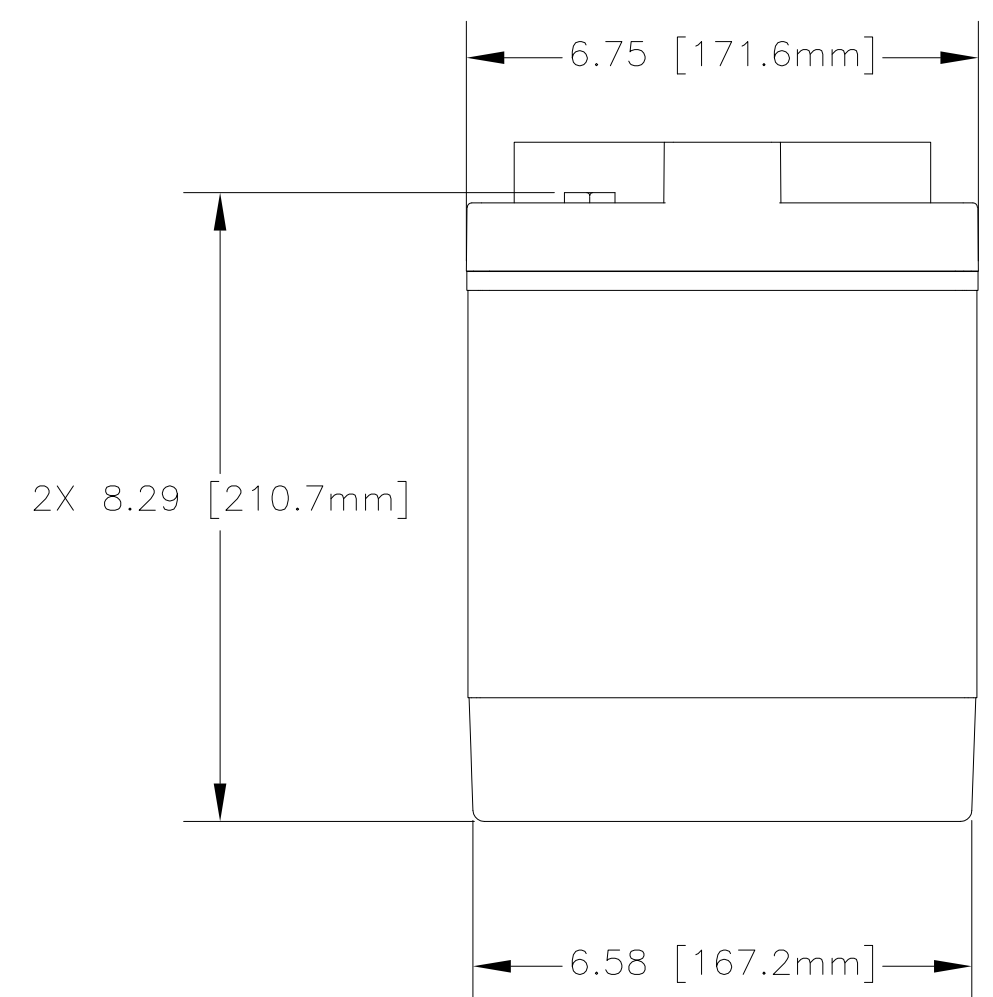
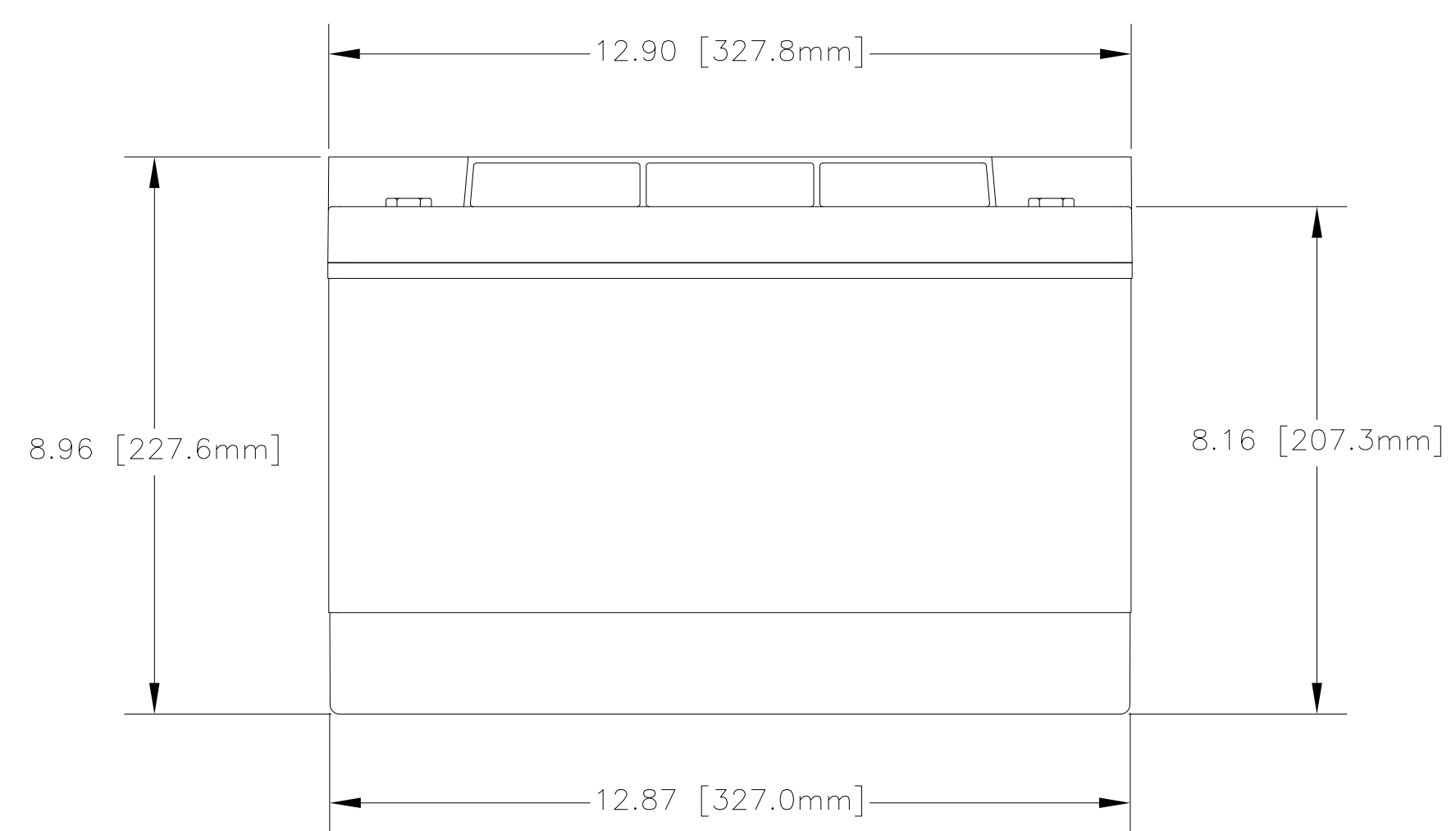
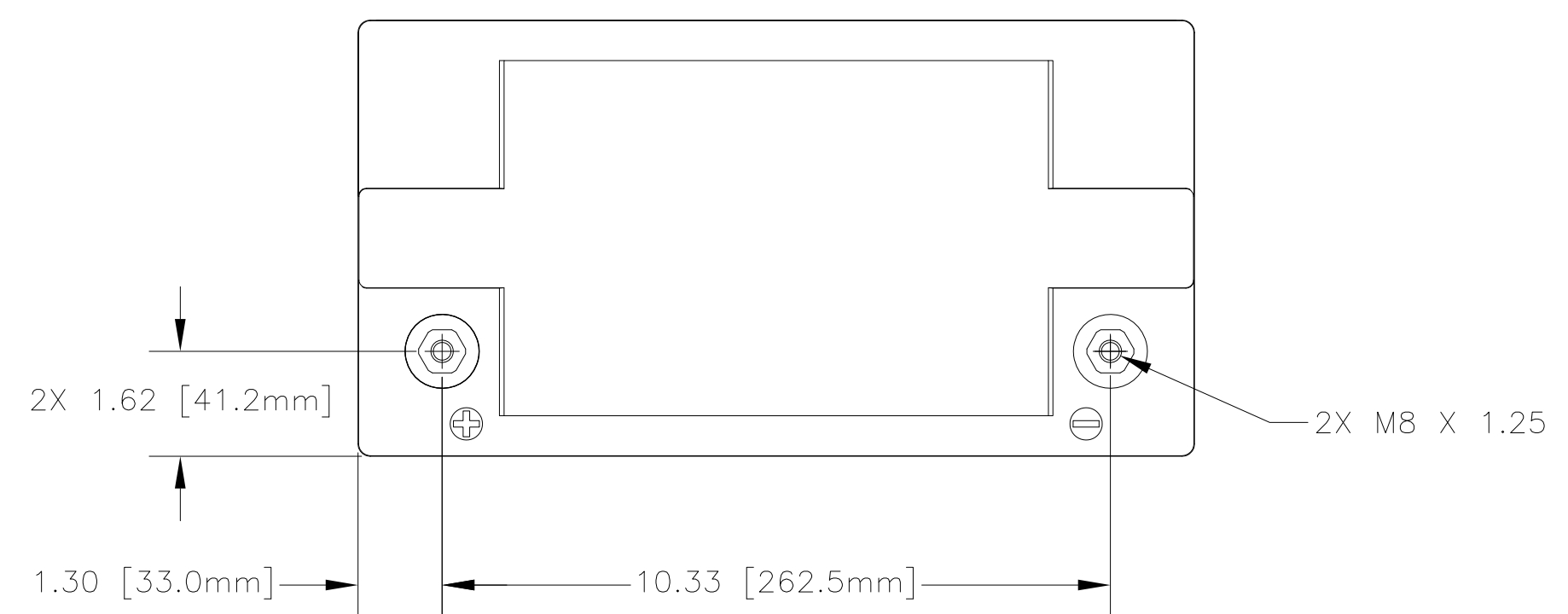

ENVELOPE DRAWING

CAPACITY RATINGS		
PART NUMBER	PVX-890T	PVX-1080T
NOMINAL WEIGHT	62 LBS [28.2 KG]	65 LBS [29.5 KG]
AMPERE HOUR CAPACITY @ 24 HOUR 1.75 VOLTS/CELL @ 77°F (25°C)	89 AH	108 AH

QTY REQD	CAGE CODE	PART OR IDENTIFYING NO.	NOMENCLATURE OR DESCRIPTION	MATERIAL SPECIFICATION	ITEM NO.
PARTS LIST					
UNLESS OTHERWISE SPECIFIED DIMENSIONS ARE IN INCHES TOLERANCES ARE: FRACTIONS DECIMALS ANGLES ± 1/32 .XX ± .06 ± 1° .XXX ± .030			CONCORDE BATTERY CORPORATION 2009 SAN BERNARDINO RD, W. COVINA, CA 91790		
APPROVALS		DATE		TITLE	
DRAWN	ELH	8/13/01		BATTERY, SLA, 12 VOLT, PVX-1080T SERIES	
CHECKED		8/21/01		SIZE	CAGE CODE
APPROVED		8/23/01		C	63017
SIMILAR TO		ACT WT	CALC WT	DWG NO.	REV
				PVX-1080T	B
ISSUED				SCALE	SHEET
JG				NONE	1 OF 1