

NOTES: UNLESS OTHERWISE SPECIFIED

1. SEE DRAWING NO. CB-00281 AND PROCEDURE P-1000 FOR ASSEMBLY AND TEST INSTRUCTION. PROCEDURES AND ASSEMBLY DRAWING ARE FOR INTERNAL USE ONLY.
2. ALL TESTING IS PERFORMED IAW BATTERY COUNCIL INTERNATIONAL STANDARDS.
3. ALL DIMENSIONS ARE IN INCHES [MM]
4. ABBREVIATION USED IN TITLE IS: SEALED LEAD ACID (SLA)
5. TERMINAL HARDWARE KIT PROVIDED, PART NUMBER 6923

REVISIONS			
REV	DESCRIPTION	DATE	APPROVED
A	CHANGED HANDLE DIRECTION	2/26/07	JBT
B	CHANGED COVER & HANDLE	11/6/07	JBT
C	REVISED TERMINAL DAMS, TERMINAL HEIGHT & HANDLES	9/16/09	JBT

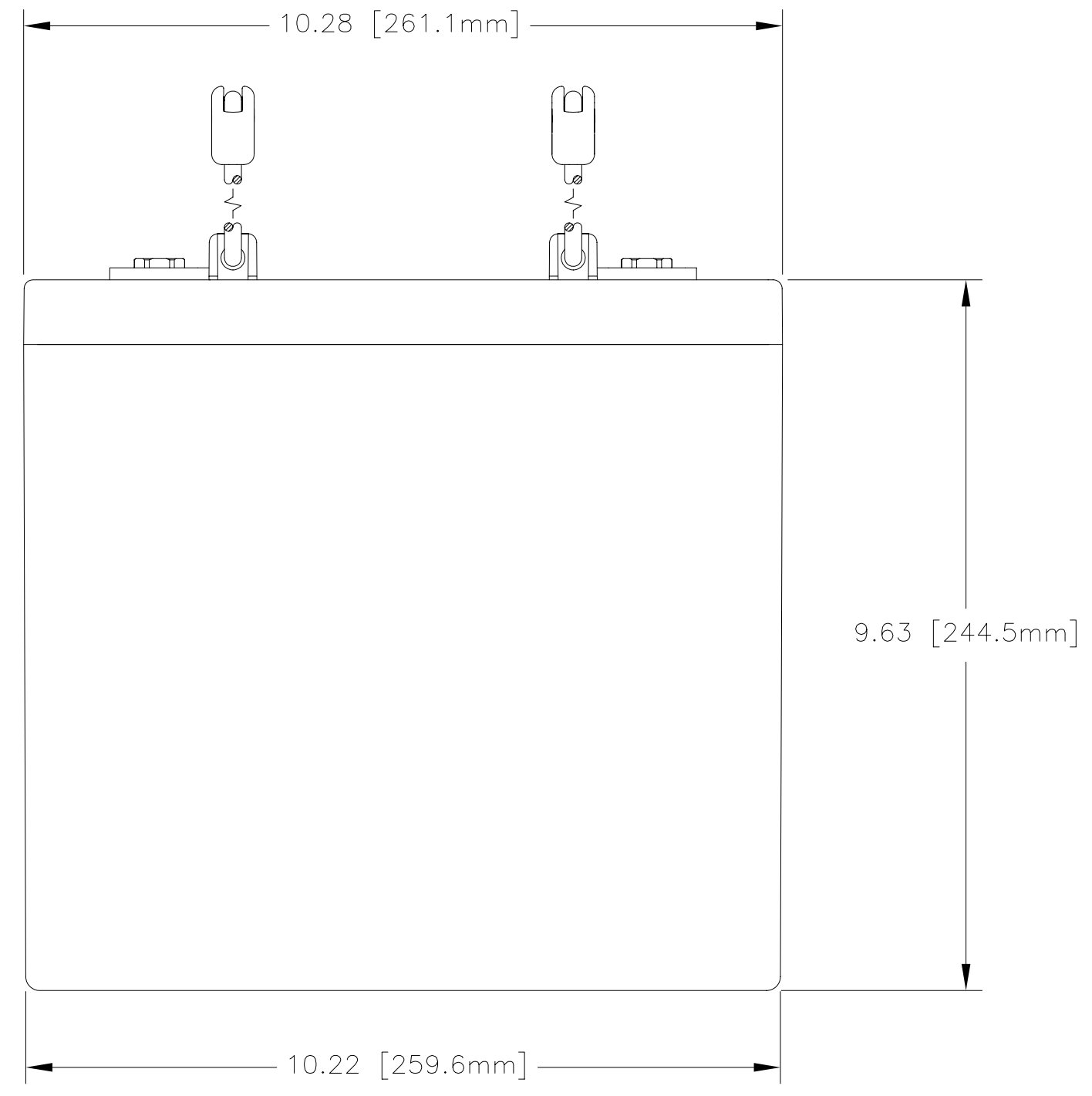
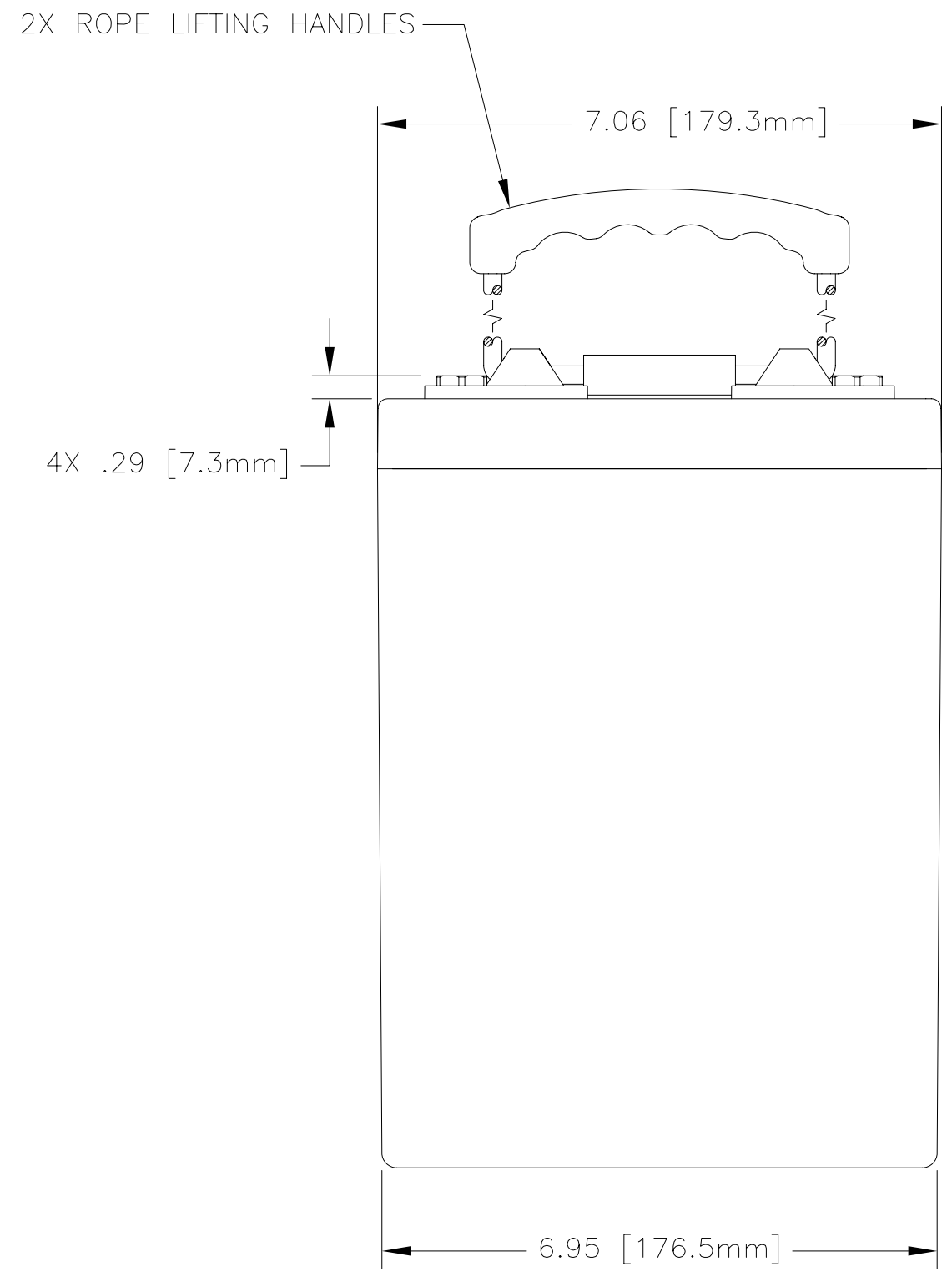
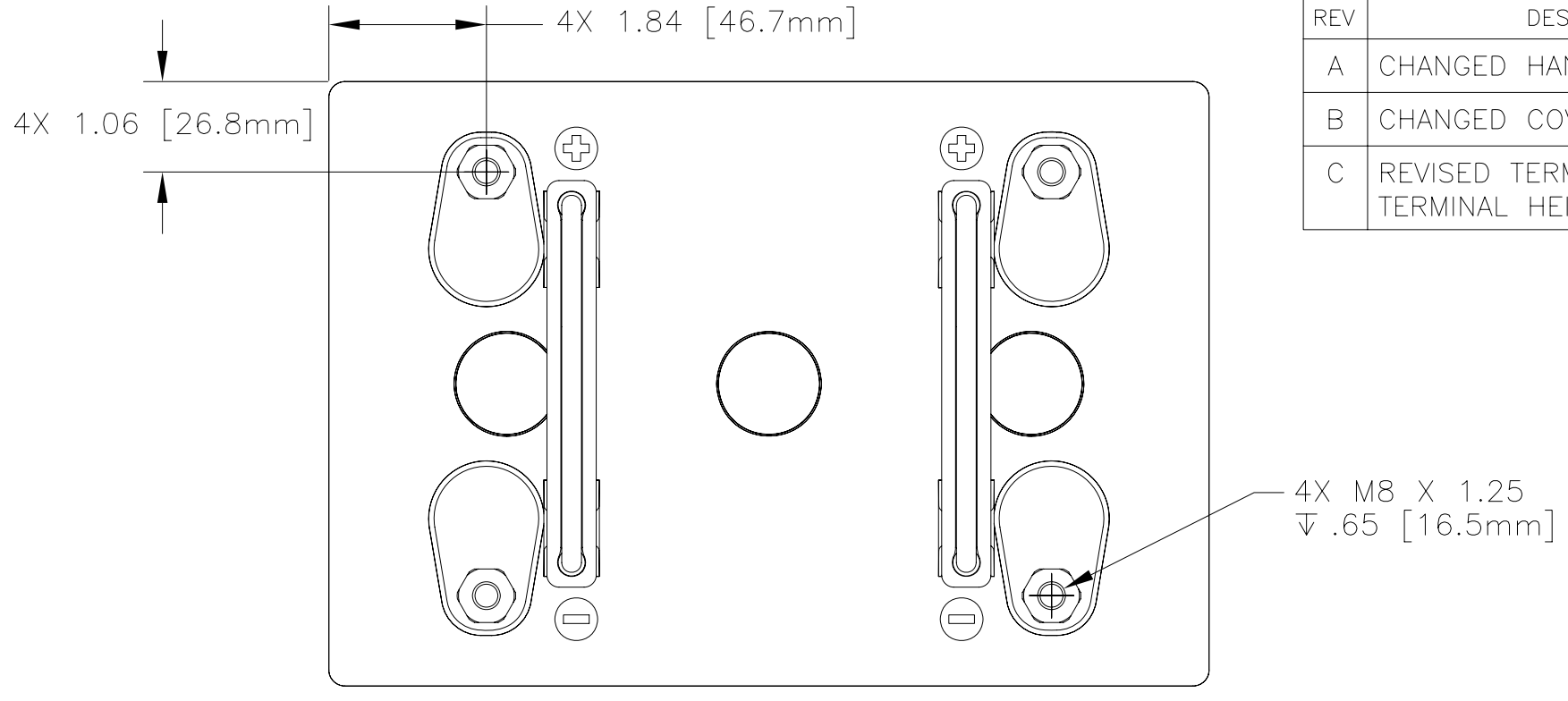

ENVELOPE DRAWING

CAPACITY RATINGS	
PART NUMBER	PVX-6720T
NOMINAL WEIGHT	70 LBS [31.8 KG]
AMPERE HOUR CAPACITY @ 24 HOUR 1.75 VOLTS/CELL @ 77°F (25° C)	672 AH

QTY REQD	CAGE CODE	PART OR IDENTIFYING NO.	NOMENCLATURE OR DESCRIPTION	MATERIAL SPECIFICATION	ITEM NO.
PARTS LIST					
UNLESS OTHERWISE SPECIFIED DIMENSIONS ARE IN INCHES TOLERANCES ARE:			CONCORDE BATTERY CORPORATION 2009 SAN BERNARDINO RD, W. COVINA, CA 91790		
FRACTIONS ± 1/32		DECIMALS .XX ± .12	ANGLES ± 1°	TITLE BATTERY, SLA, 2 VOLT, PVX-6720T	
TREATMENT NONE		CHECKED AMIII	1/9/07	SIZE C	CAGE CODE 63017
FINISH NONE		APPROVED JBT	1/10/07	DWG NO. PVX-6720T	REV C
SIMILAR TO N/A		ACT WT N/A	CLC WT N/A	ISSUED JJ	9/18/09
SCALE 1/2				SHEET 1 OF 1	