

NOTES: UNLESS OTHERWISE SPECIFIED

1. SEE DRAWING NO. CB-00280 AND PROCEDURE P-1000 FOR ASSEMBLY AND TEST INSTRUCTION. PROCEDURES AND ASSEMBLY DRAWINGS ARE FOR INTERNAL USE ONLY.
2. ALL TESTINGS ARE IAW BATTERY COUNCIL INTERNATIONAL STANDARDS.
3. ALL DIMENSIONS ARE IN INCHES [MM].
4. ABBREVIATION USED IN TITLE IS: SEALED LEAD ACID (SLA).

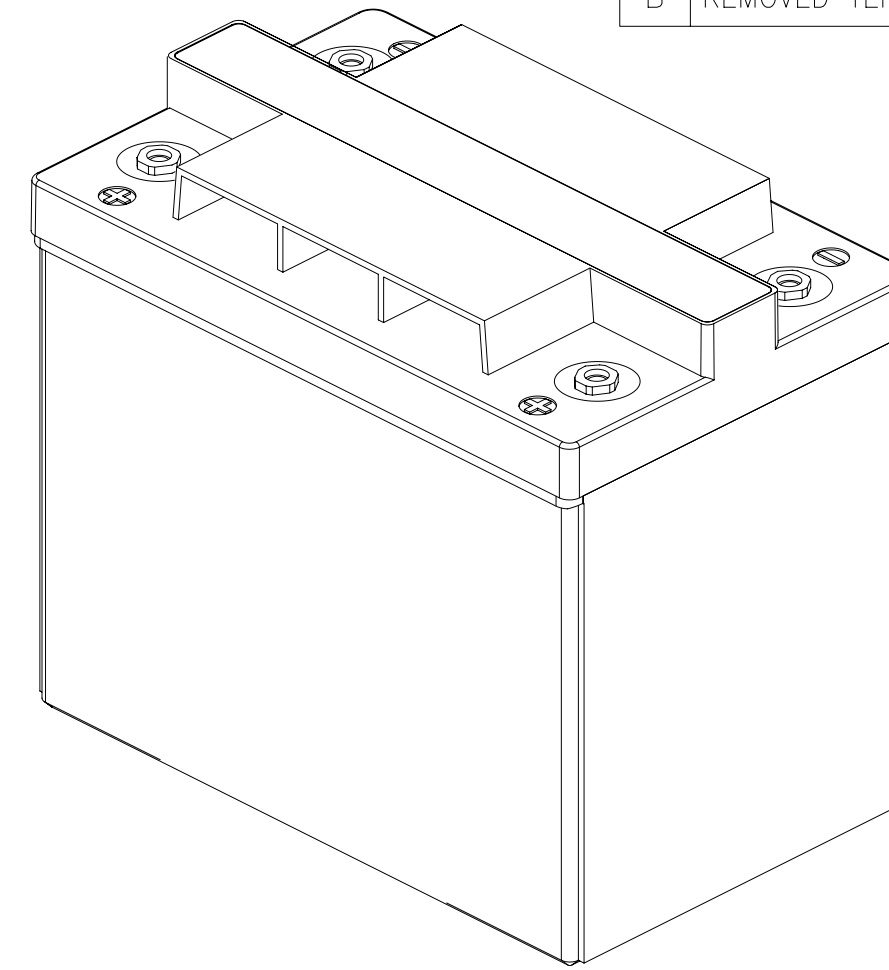

REFERENCE VIEW

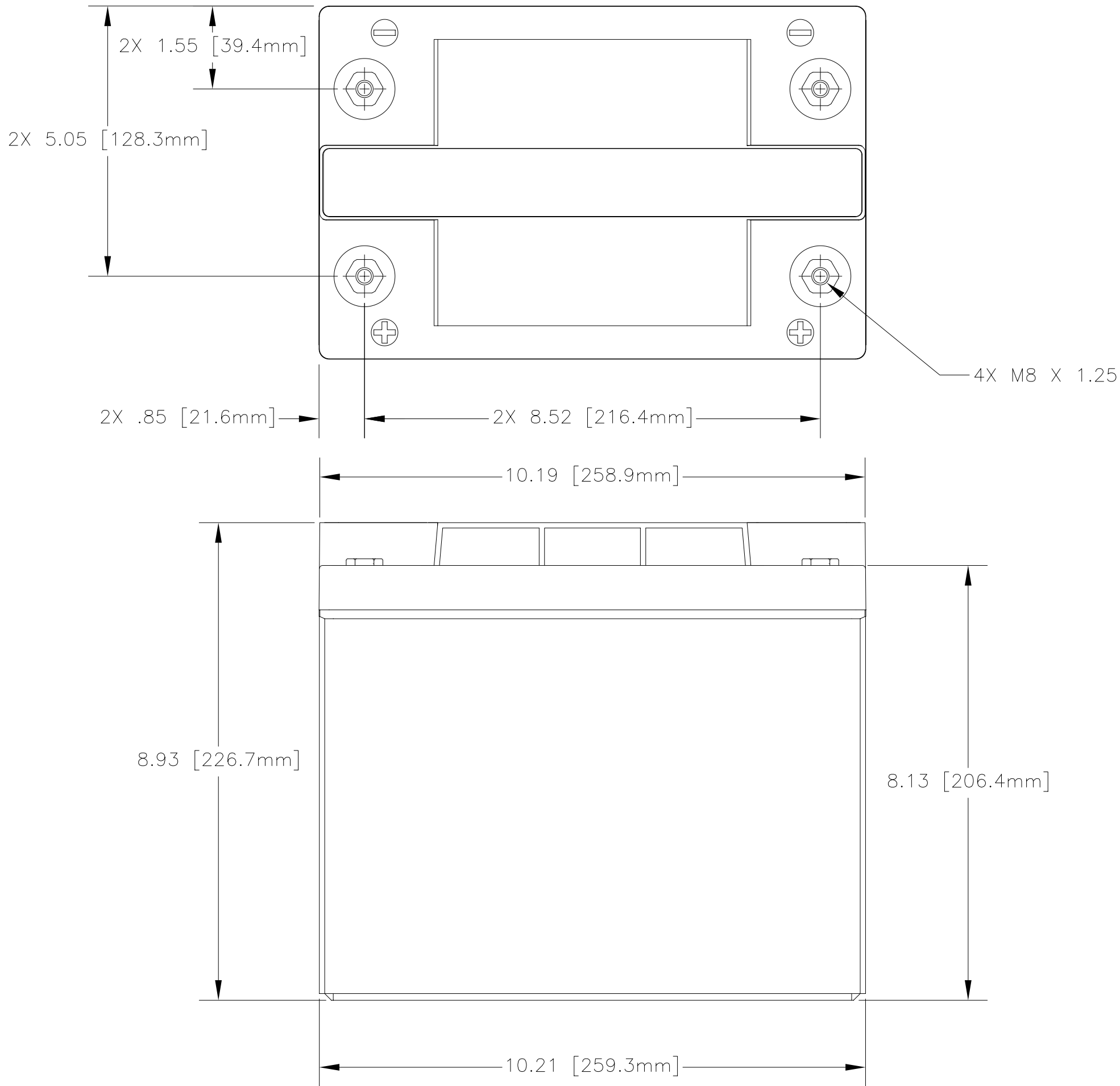
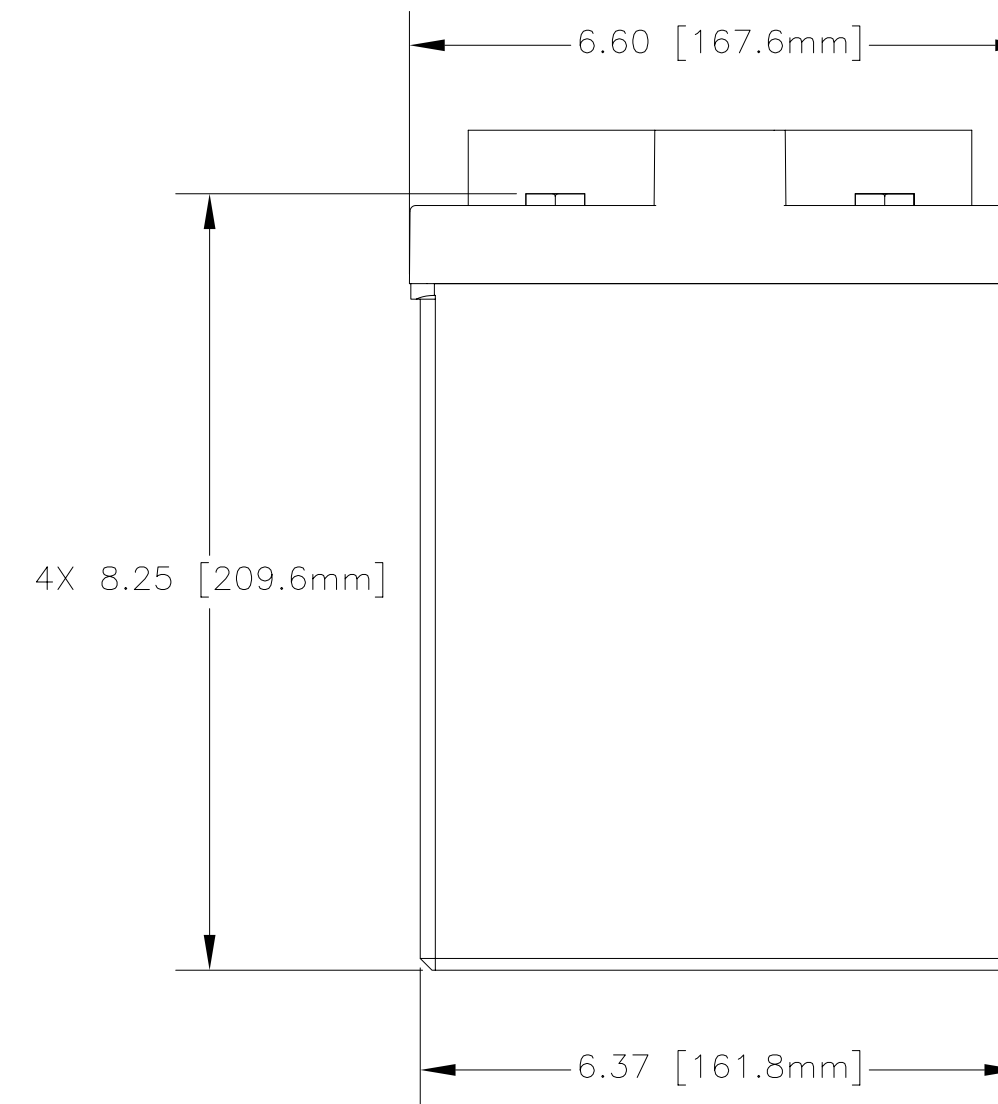

ENVELOPE DRAWING

REVISIONS			
REV	DESCRIPTION	DATE	APPROVED
A	REMOVED SIDE HOLD-DOWNS	6/10/03	JBT
B	REMOVED TERMINAL PROTECTORS	8/30/06	JBT

CAPACITY RATINGS		
PART NUMBER	PVX-4140T	PVX-5040T
NOMINAL WEIGHT	51 LBS [23.2 KG]	57 LBS [25.9 KG]
AMPERE HOUR CAPACITY @ 24 HOUR 1.75 VOLTS/CELL @ 77°F (25°C)	414 AH	504 AH

QTY REQD	CAGE CODE	PART OR IDENTIFYING NO.	NOMENCLATURE OR DESCRIPTION	MATERIAL SPECIFICATION	ITEM NO.
PARTS LIST					
UNLESS OTHERWISE SPECIFIED DIMENSIONS ARE IN INCHES. TOLERANCES ARE:		CONTRACT NO. NA		CONCORDE BATTERY CORPORATION 2009 SAN BERNARDINO RD, W. COVINA, CA 91790	
FRACTIONS	DECIMALS	ANGLES	APPROVALS	DATE	TITLE
± 1/32	.XX ± .06	± 1°	ELH	8/13/01	BATTERY, SLA, 2 VOLT, PVX-5040T SERIES
	.XXX ± .030		CHECKED	HRF	8/21/01
TREATMENT	NONE	APPROVED	JBT	8/23/01	SIZE CAGE CODE
FINISH	NONE	ISSUED	NS	9/5/06	63017 DWG NO. PVX-5040T
SIMILAR TO NA	ACT WT NA	CALC WT NA			SCALE NONE
				SHEET	1 OF 1

ENGINEERING COPY 05SEP06