

NOTES: UNLESS OTHERWISE SPECIFIED

1. SEE DRAWING NO. CB-00290 AND PROCEDURE P-1000 FOR ASSEMBLY AND TEST INSTRUCTION. PROCEDURES AND ASSEMBLY DRAWINGS ARE FOR INTERNAL USE ONLY.
2. ALL TESTING IS PERFORMED IAW BATTERY COUNCIL INTERNATIONAL STANDARDS.
3. ALL DIMENSIONS ARE INCH [MM]
4. ABBREVIATION USED IN TITLE IS: SEALED LEAD ACID (SLA)

REVISIONS			
REV	DESCRIPTION	DATE	APPROVED
C	REDESIGNED COVER	12/18/17	PH

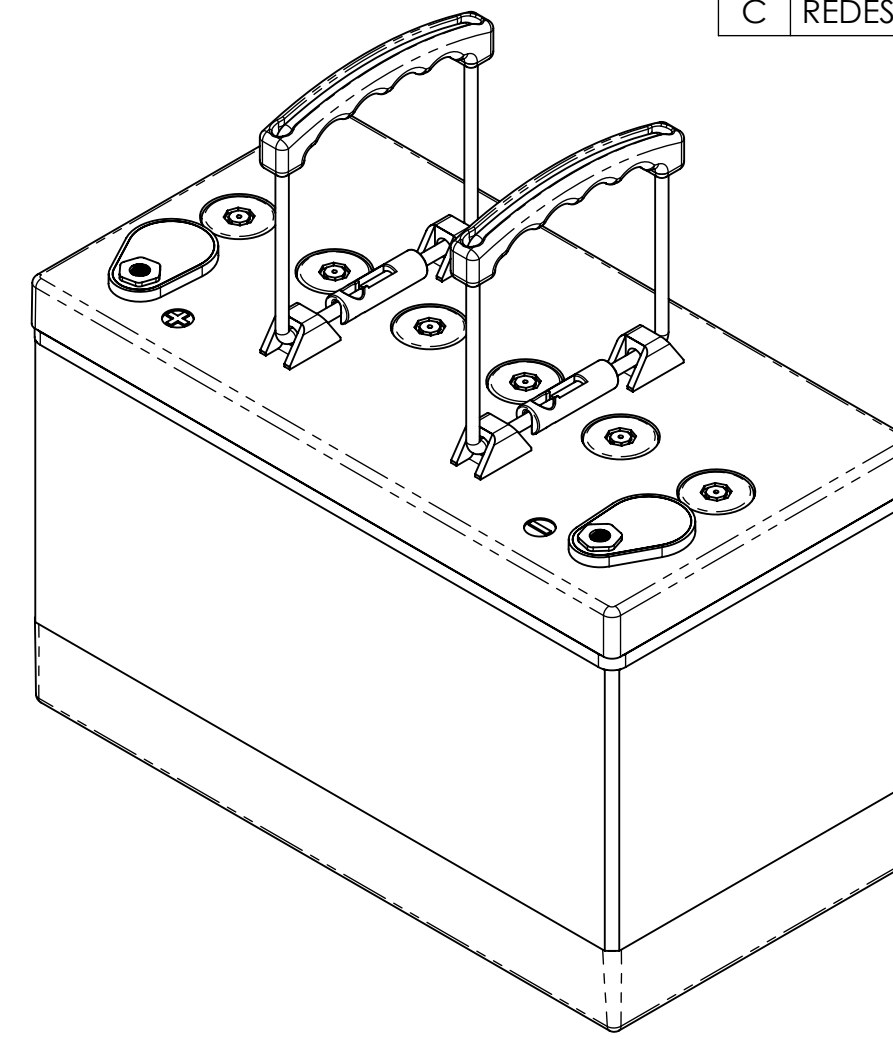

ISOMETRIC VIEW

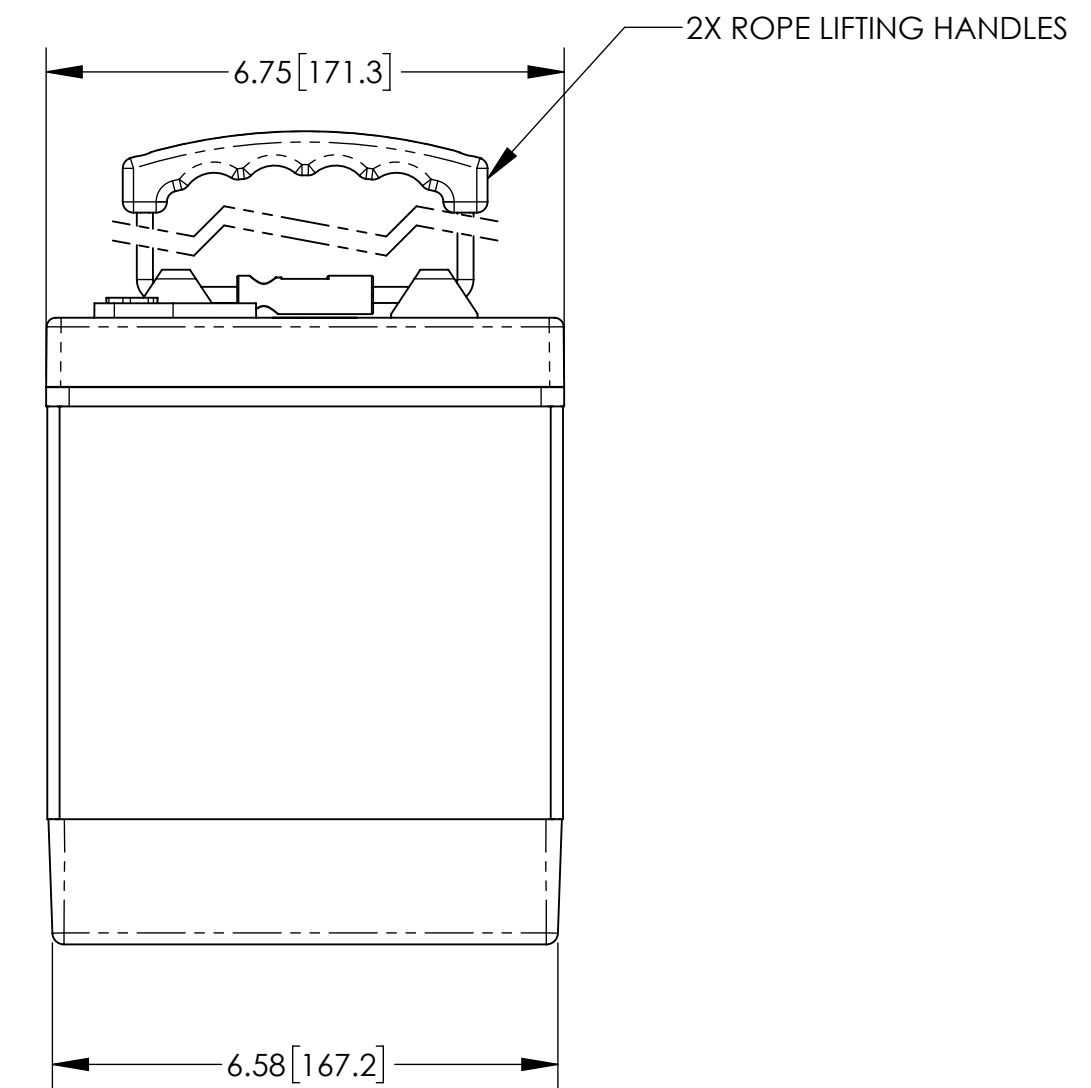
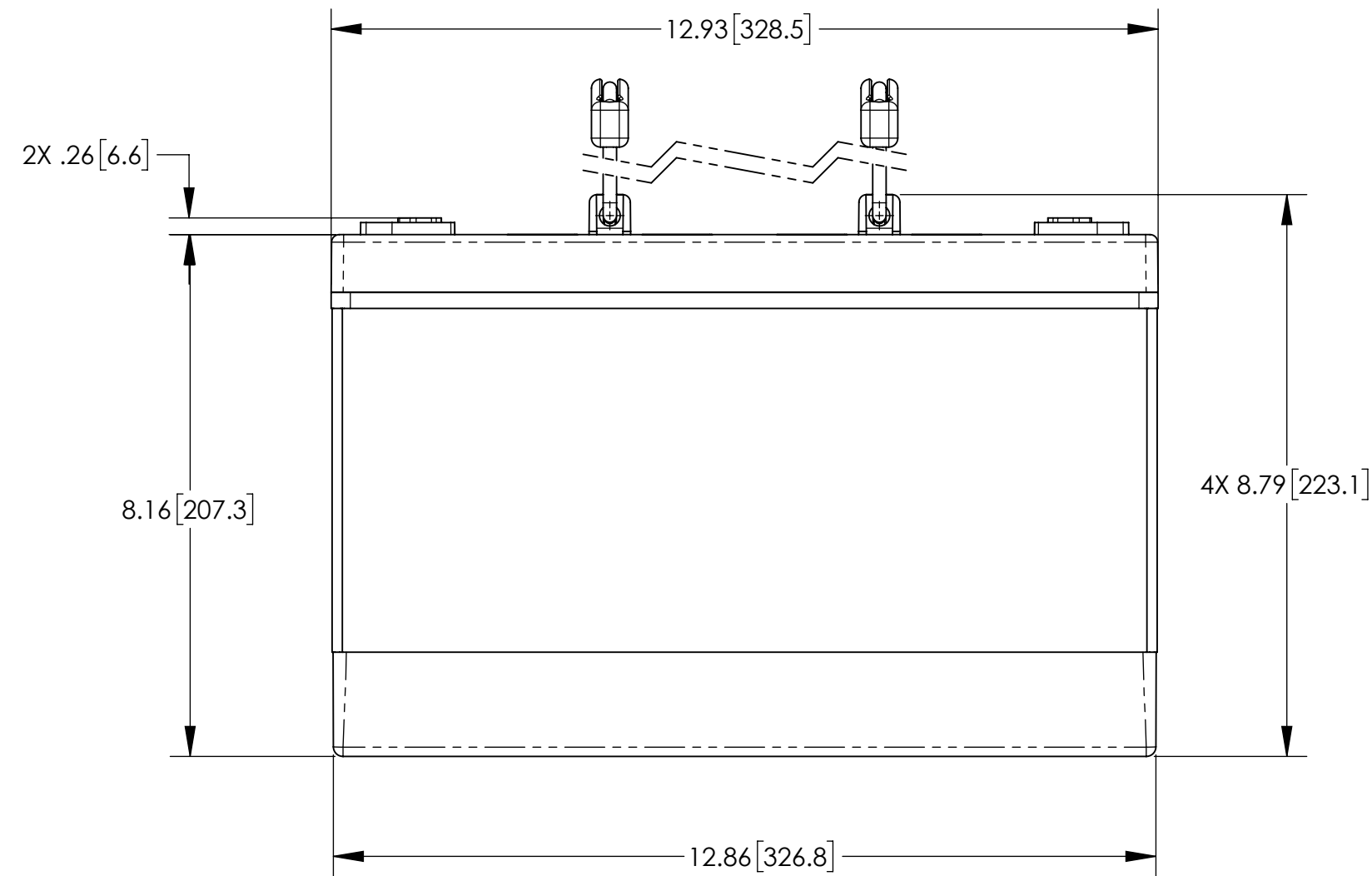
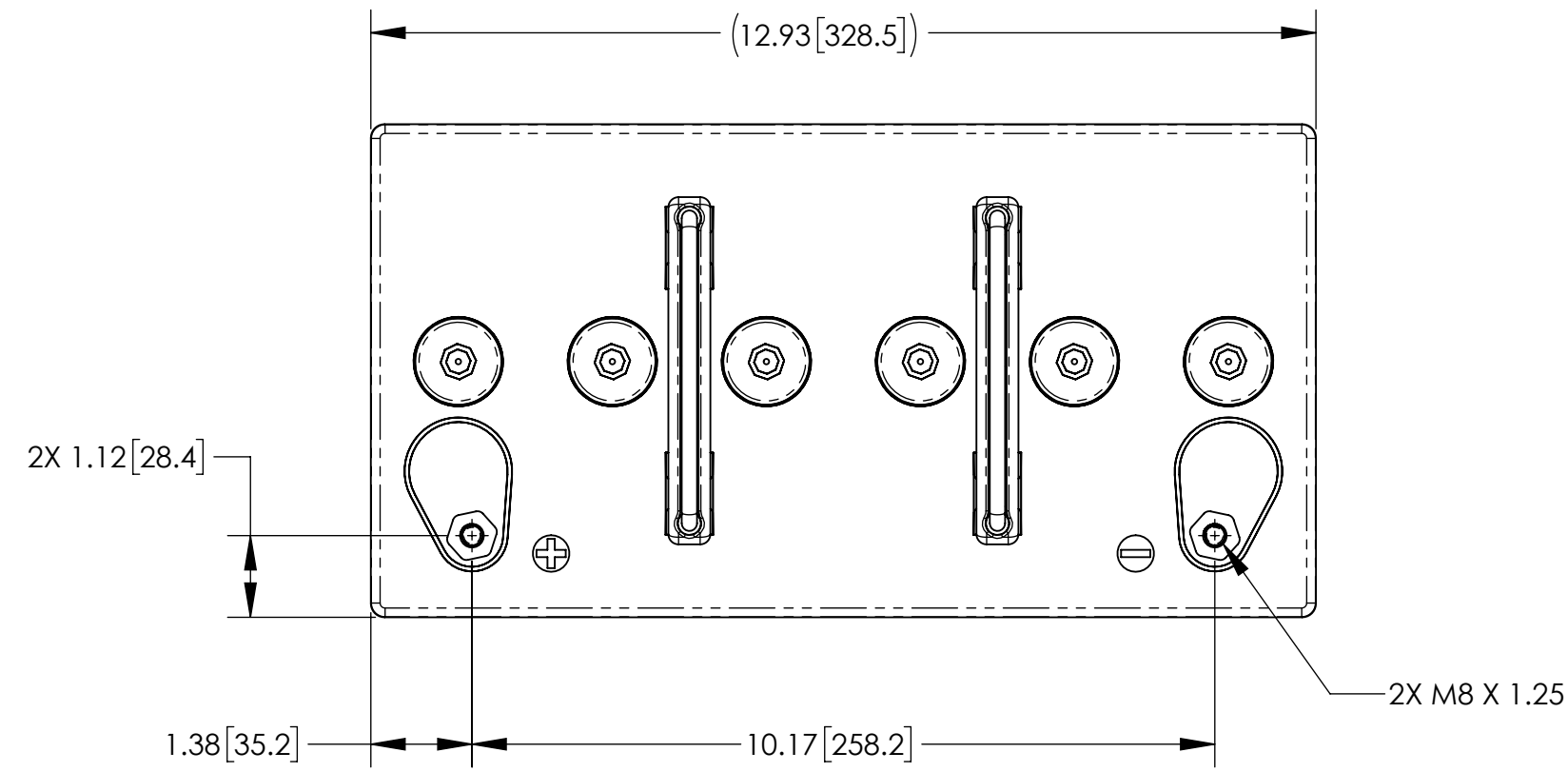

CAPACITY RATINGS		
PART NUMBER	PVX-890T	PVX-1080T
NOMINAL WEIGHT	62 LBS [28.2 KG]	65 LBS [29.2 KG]
AMPERE HOUR CAPACITY @ 24 HOUR 1.75 VOLTS/CELL @ 77°F (25°C)	89 AH	108 AH

ENVELOPE DRAWING

UNLESS OTHERWISE SPECIFIED DIMENSIONS ARE IN INCHES TOLERANCES ARE:			CONTRACT NO.		CONCORDE BATTERY CORPORATION 2009 SAN BERNARDINO RD, W. COVINA, CA 91790			
FRACTIONS	DECIMALS	ANGLES	APPROVALS		DATE		TITLE	
±1/32	.XX ± .06 .XXX ± .030	±1°	DRAWN ELH		8/13/01		BATTERY, SLA, 12 VOLT, PVX-1080T SERIES	
TREATMENT	NONE		CHECKED HRF		8/21/01		SIZE	REV
FINISH	NONE		APPROVED JBT		8/23/01		CAGE CODE	C
SIMILAR TO	CALC WT		ISSUED JG		12/19/17		DWG NO.	
							PVX-1080T	
SCALE 1:2.5							SHEET 1 OF 1	