

NOTES: UNLESS OTHERWISE SPECIFIED

1. SEE DRAWING NO. CB-00285 AND PROCEDURE P-1000 FOR ASSEMBLY AND TEST INSTRUCTION. PROCEDURES AND ASSEMBLY DRAWINGS ARE FOR INTERNAL USE ONLY.
2. ALL TESTING IS PERFORMED IAW BATTERY COUNCIL INTERNATIONAL STANDARDS.
3. ALL DIMENSIONS ARE INCH [MM].
4. ABBREVIATION USED IN TITLE IS: SEALED LEAD ACID (SLA).

REVISIONS			
REV	DESCRIPTION	DATE	APPROVED
C	SEE DCN PVX1040HTC	8/10/11	JBT

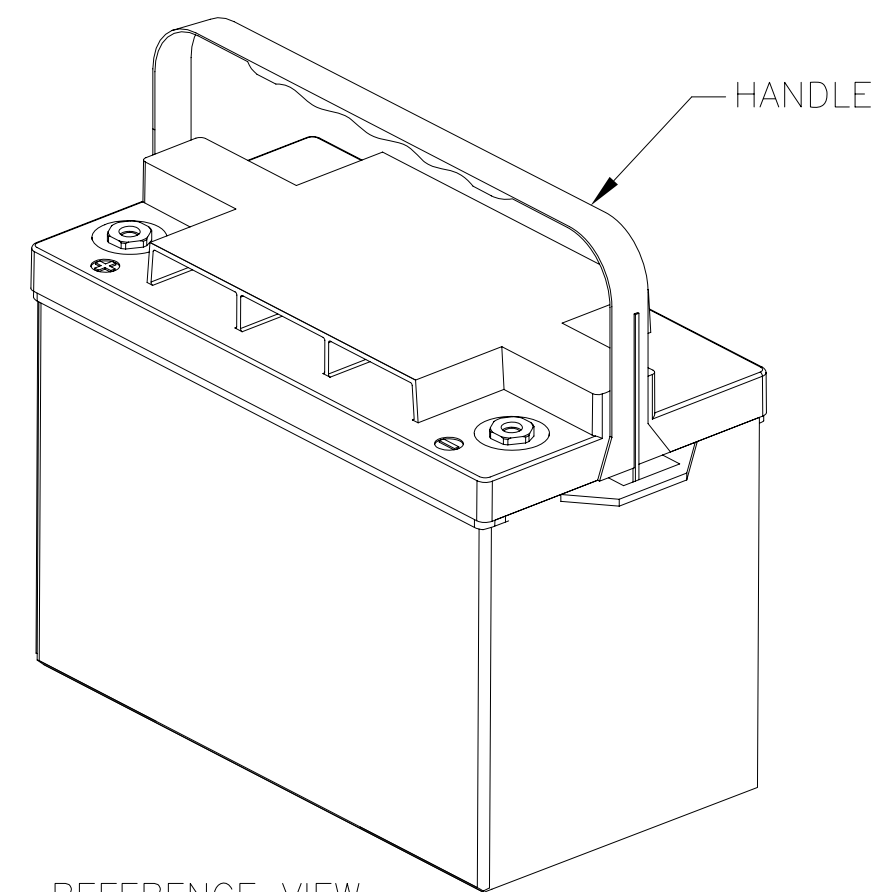
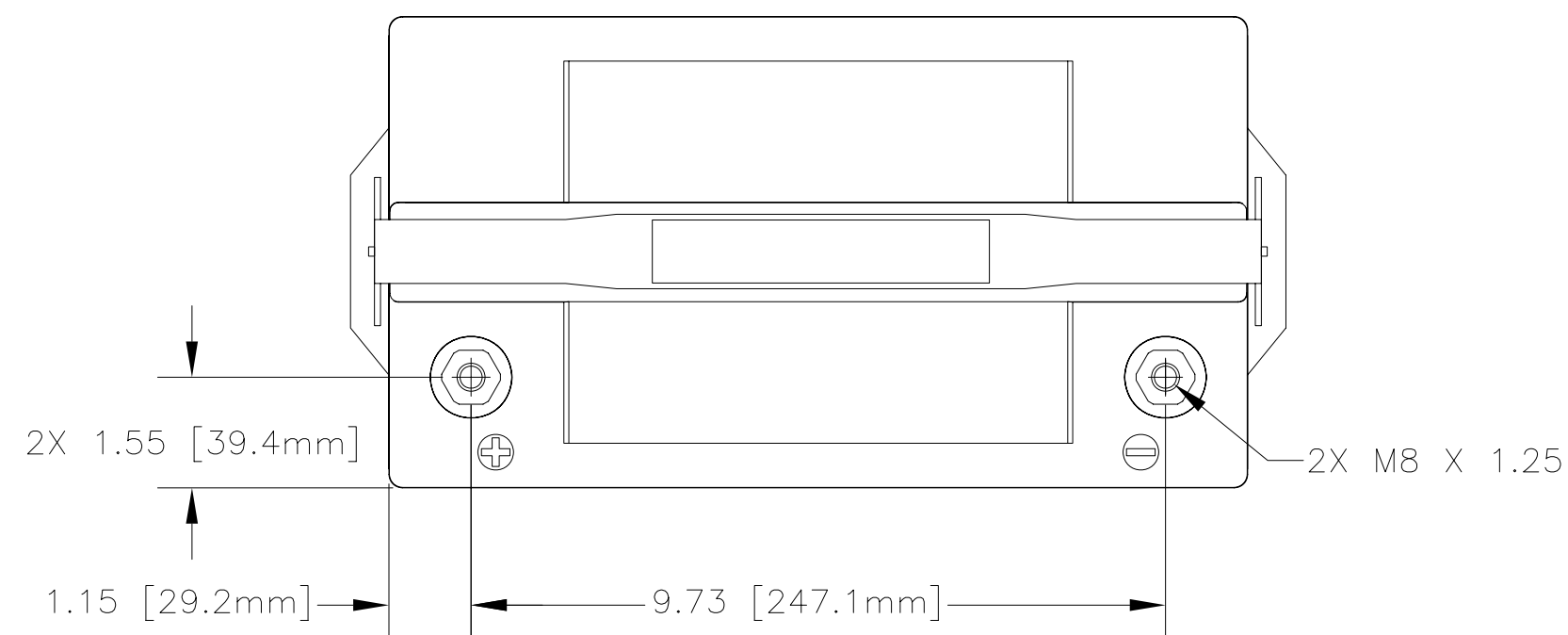

REFERENCE VIEW

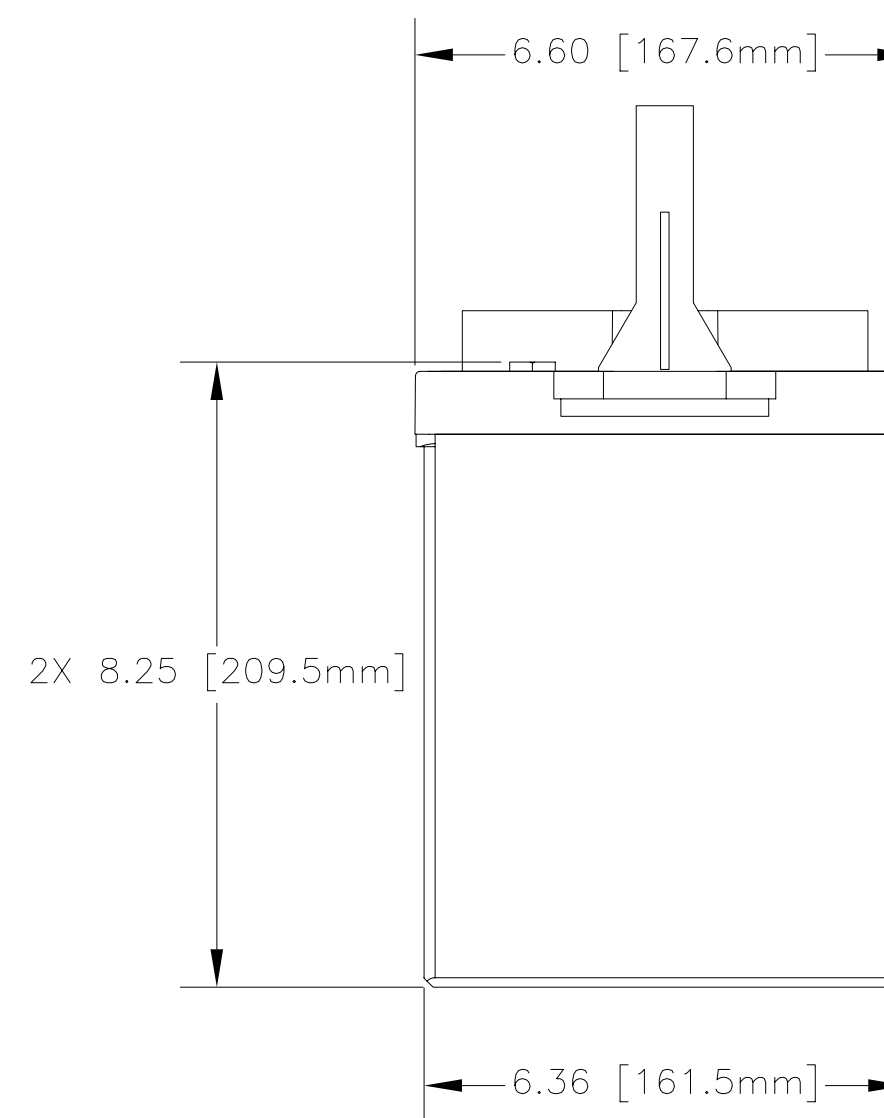
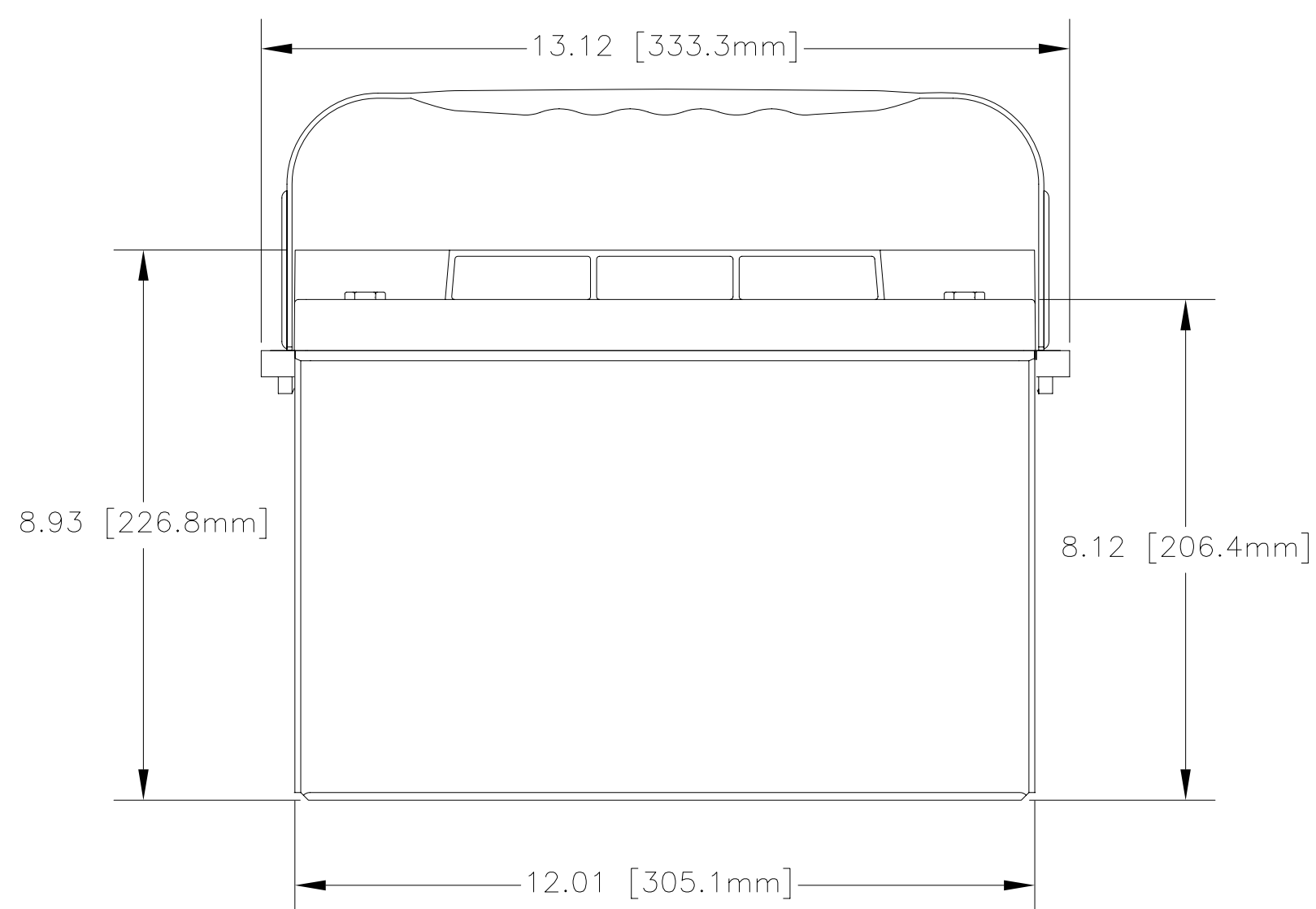

ENVELOPE DRAWING

CAPACITY RATINGS	
PART NUMBER	PVX-1040HT
NOMINAL WEIGHT	63 LBS [28.6 KG]
AMPERE HOUR CAPACITY @ 24 HOUR 1.75 VOLTS/CELL @ 77°F (25°C)	104 AH

QTY REQD	CAGE CODE	PART OR IDENTIFYING NO.	NOMENCLATURE OR DESCRIPTION	MATERIAL SPECIFICATION	ITEM NO.
PARTS LIST					
UNLESS OTHERWISE SPECIFIED DIMENSIONS ARE IN INCHES TOLERANCES ARE: FRACTIONS DECIMALS ANGLES ± 1/32 .XX ± .06 ± 1° .XXX ± .030			CONCORDE BATTERY CORPORATION 2009 SAN BERNARDINO RD, W. COVINA, CA 91790		
TREATMENT NONE		APPROVALS	DATE	TITLE	
FINISH NONE		DRAWN S.FRAZIER	11/7/02	BATTERY, SLA, 12 VOLT, PVX-1040HT	
SIMILAR TO		CHECKED HRF	11/8/02	SIZE C	CAGE CODE 63017
ACT WT		APPROVED JBT	11/15/02	DWG NO. PVX-1040HT	REV C
CALC WT		ISSUED JJ	8/12/11	SCALE NONE	SHEET 1 OF 1