

NOTES: UNLESS OTHERWISE SPECIFIED

1. MANUFACTURED AND INSPECTED IAW AS9100 QUALITY SYSTEM REQUIREMENTS.
2. SEE DRAWING NUMBER CB-00370 AND PROCEDURE P-1000 FOR ASSEMBLY AND TEST INSTRUCTION. PROCEDURES AND ASSEMBLY DRAWINGS ARE FOR INTERNAL USE ONLY
3. BATTERIES ARE RATED IAW INTERNATIONAL ELECTROTECHNICAL COMMISSION STANDARD 60952-1 AND RTCA DO-293, UNLESS OTHERWISE NOTED
4. THIS BATTERY IS NOT RATED FOR "ENGINE STARTING - HIGH RATE PERFORMANCE"

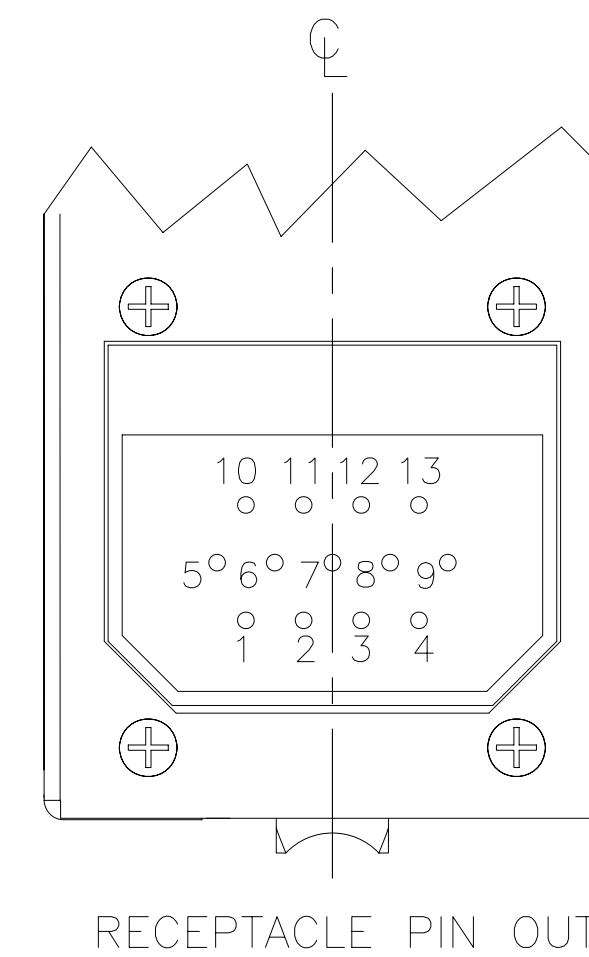

REVISIONS			
REV	DESCRIPTION	DATE	APPROVED
A	UPDATED SCHEMATIC, NOTE 4, AND RATINGS PER TSO TEST	11/5/08	JBT
B	REVISED NOTES, INTERNAL DC HEATER 4A WAS 6A, ADDED CG WITH DIMS, ISOMETRIC VIEW & ID LABEL LOCATIONS, CAPACITY RATINGS: 3.3 WAS 3.5, 2.9 WAS 3.5, J1 WAS P1	9/29/10	JBT

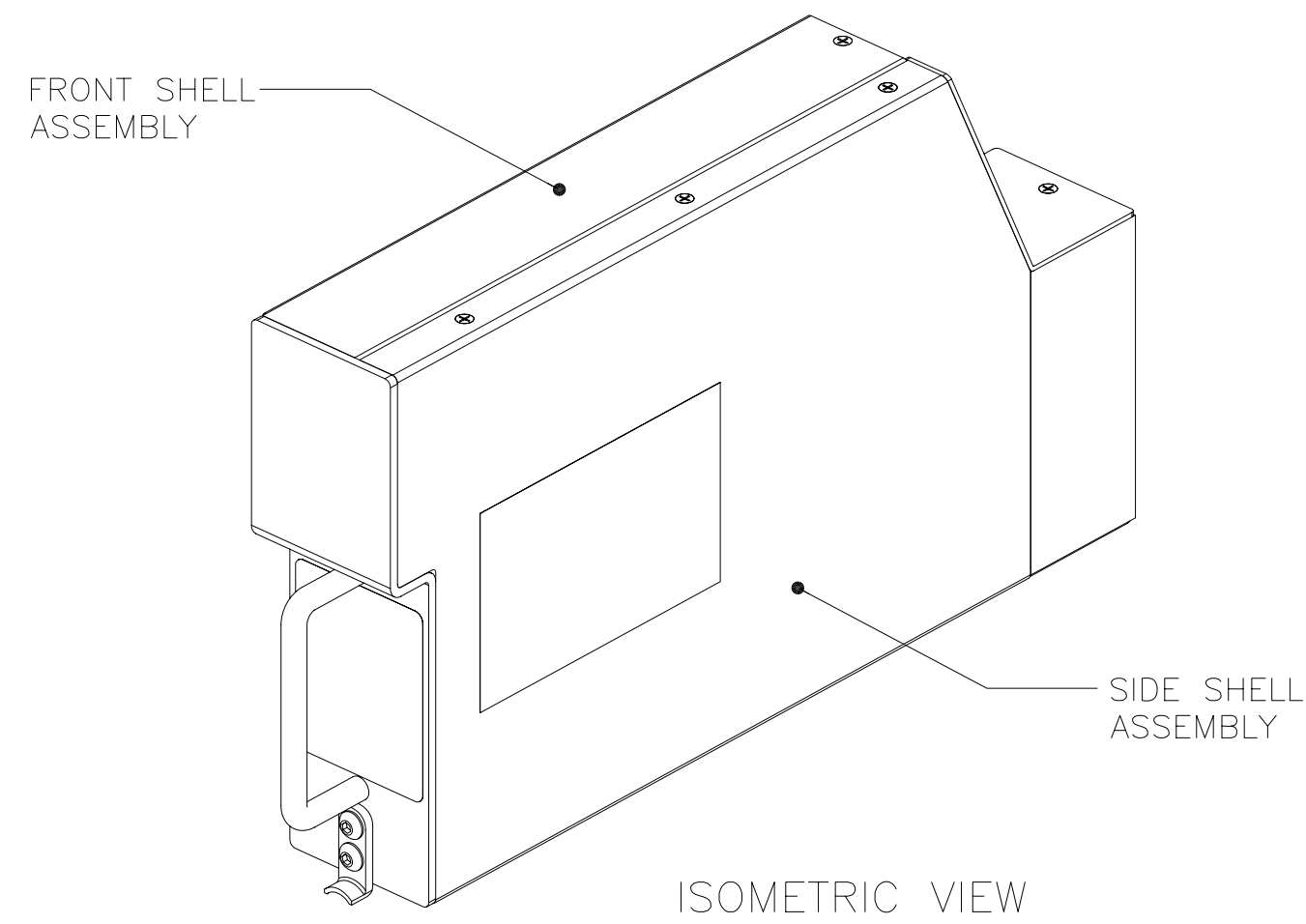
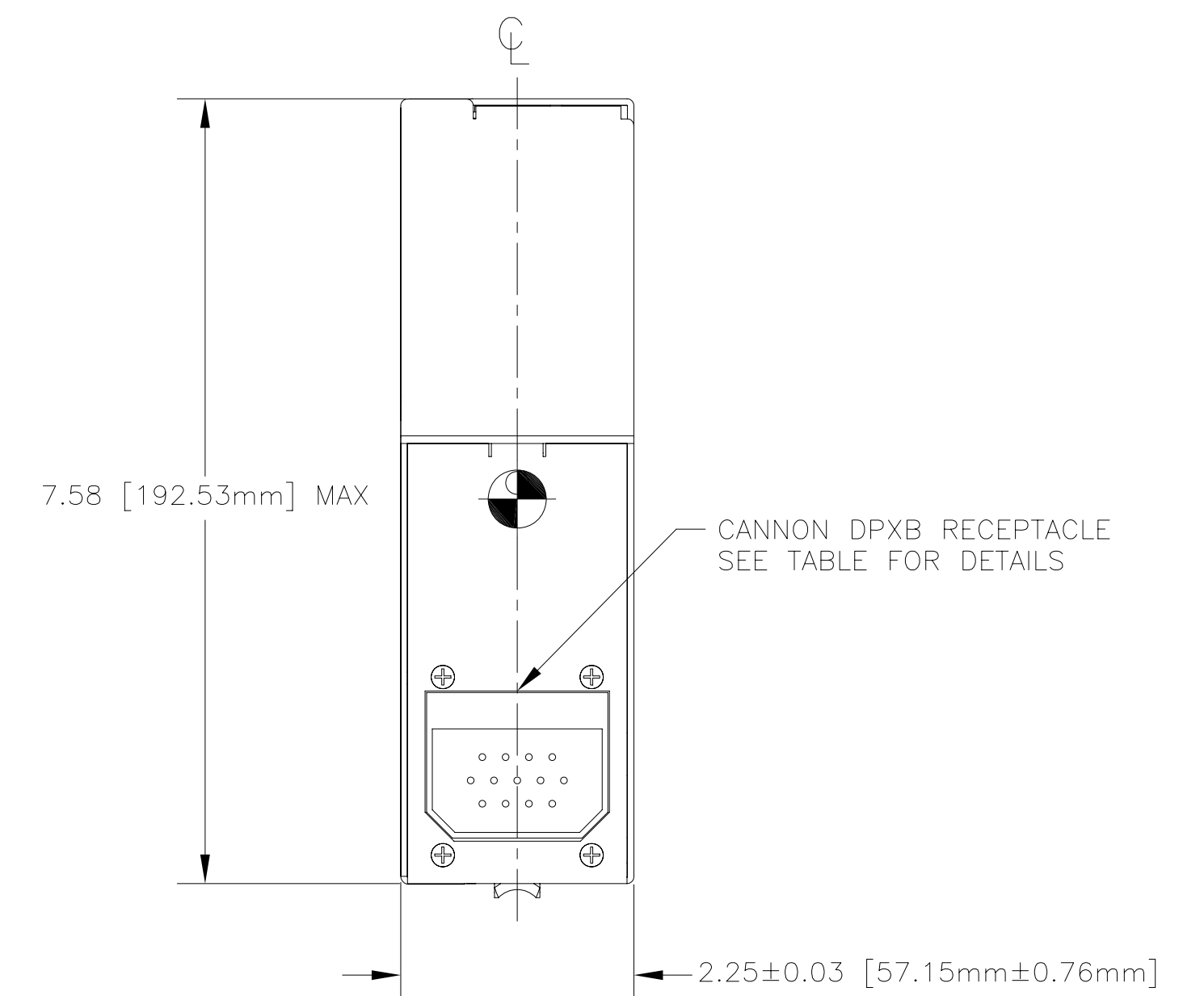
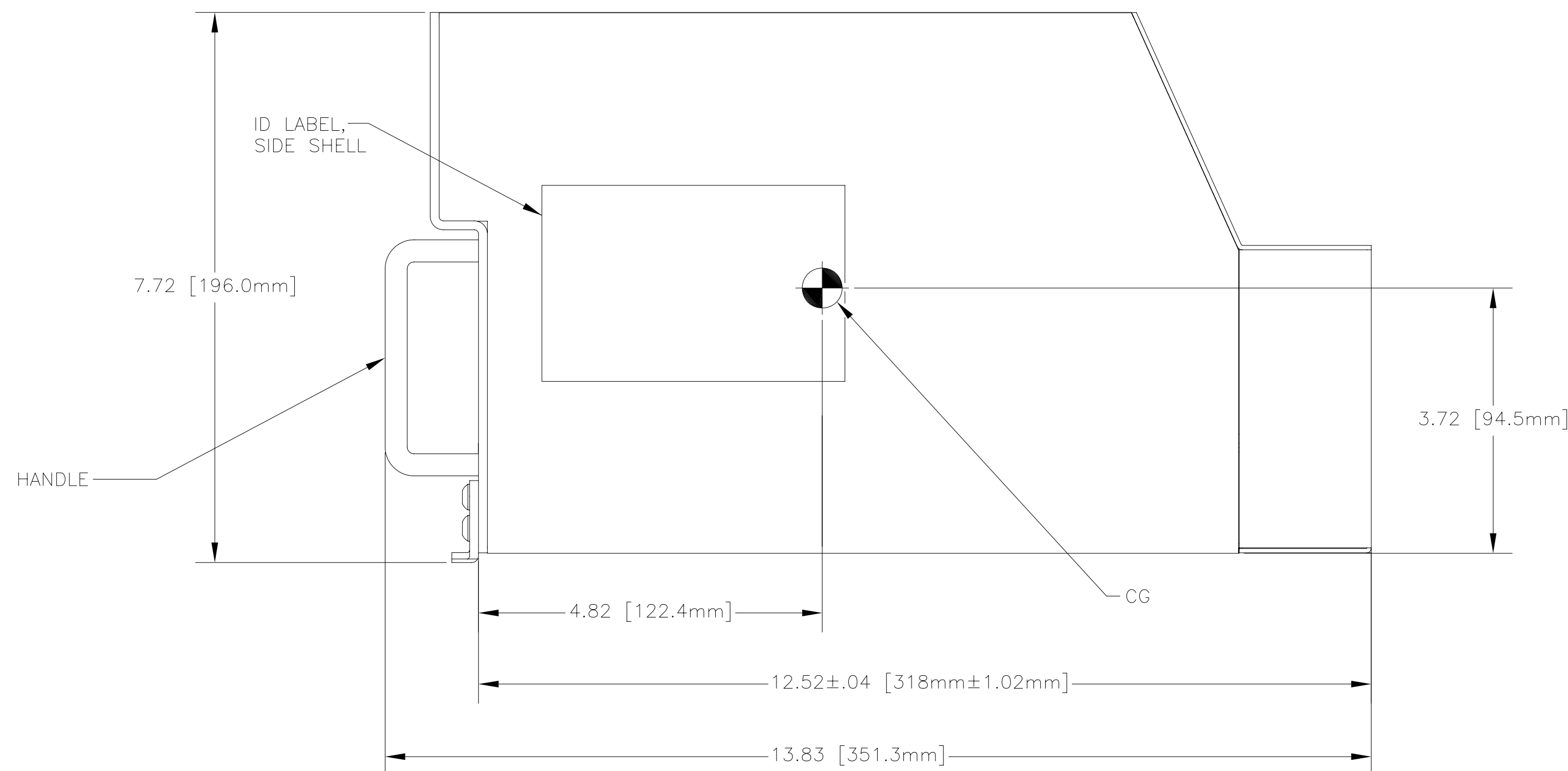
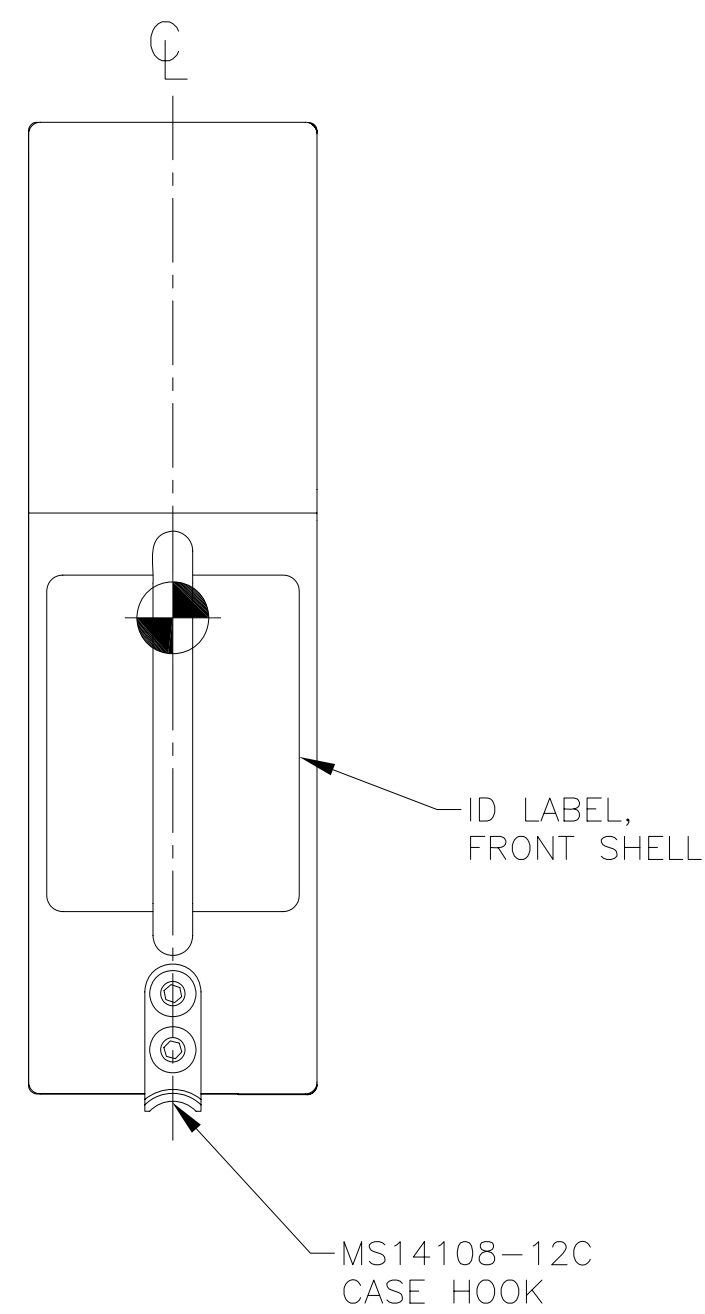

PART NUMBER	RG-1835-1	RG-1835-2
MAXIMUM WEIGHT	12.7 LBS [5.8 KG]	13.0 LBS [5.9 KG]
RATED CAPACITY, C <sub>1</sub>	3.5 AH	
CAPACITY, -18°C (0°F)	3.0 AH	3.3 AH
CAPACITY, -30°C (-22°F)	2.0 AH	2.9 AH
INPUT	28 VDC NOM.	
MAXIMUM INRUSH CURRENT	24 AMPS	
RECEPTACLE	DPXB-13-34P-0101 OR EQUAL	
INTERNAL DC HEATER	NO	4A MAX AT 28.25VDC

POWER APPLIED TO HEATERS FOR 1 HOUR PRIOR TO TEST AT LOW TEMPERATURES.

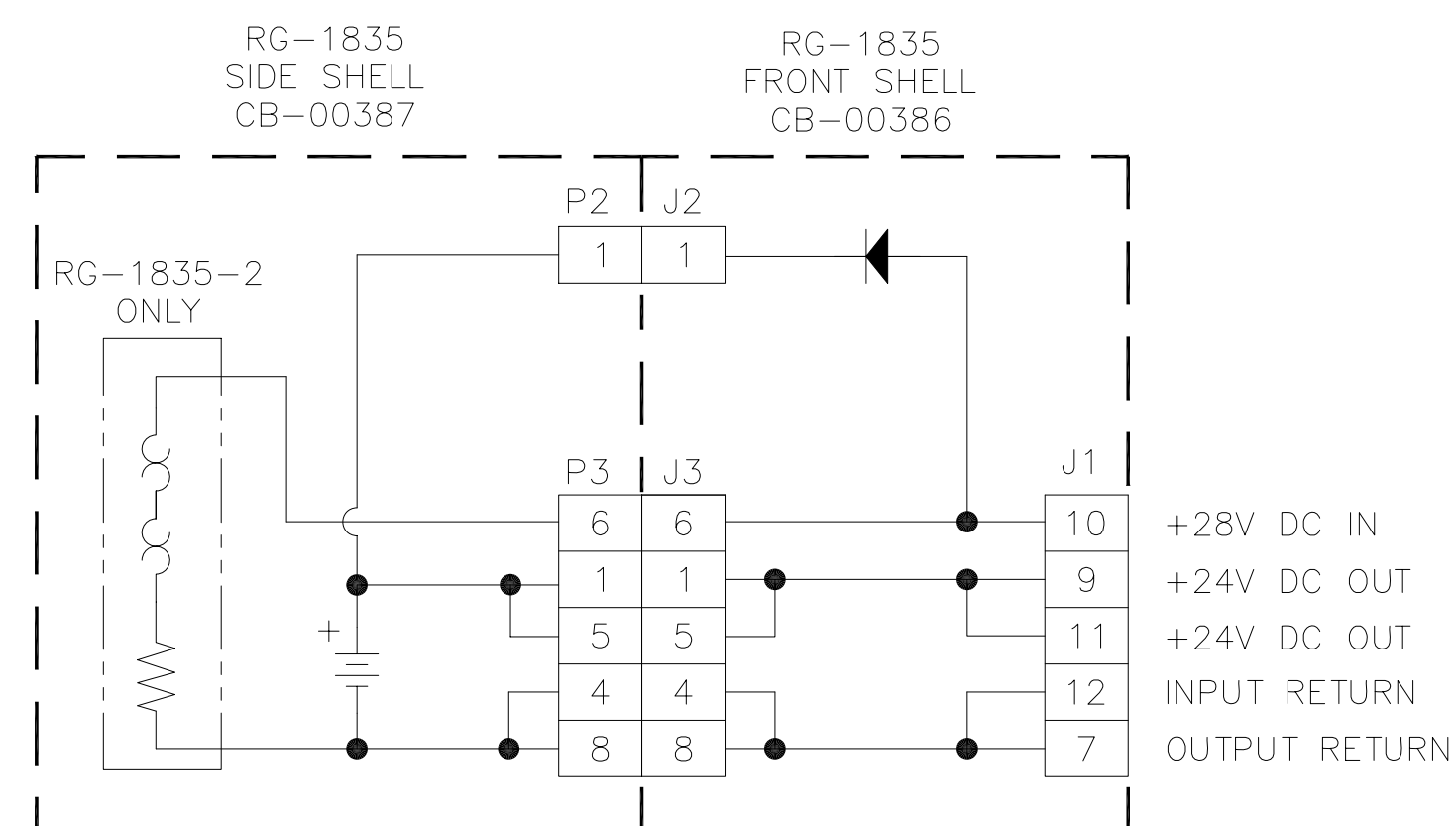

ENVELOPE DRAWING

QTY REQD	CAGE CODE	PART OR IDENTIFYING NO.	NOMENCLATURE OR DESCRIPTION	MATERIAL SPECIFICATION	ITEM NO.
PARTS LIST					
UNLESS OTHERWISE SPECIFIED DIMENSIONS ARE IN INCHES TOLERANCES ARE:			CONTRACT NO.		
FRACTIONS	DECIMALS	ANGLES	CONCORDE BATTERY CORPORATION		
±1/32	.XX ±.06	±1°	2009 SAN BERNARDINO RD, W. COVINA, CA 91790		
	.XXX ±.030		APPROVALS	DATE	TITLE
TREATMENT	NONE		DRAWN A. MISTRETTA	6/18/08	BATTERY, VRSLA, 24 VOLT, RG-1835 SERIES
FINISH	NONE		CHECKED AMIII	6/18/08	
SIMILAR TO	ACT WT	CALC WT	APPROVED JBT	6/18/08	SIZE D CAGE CODE 63017 DWG NO. RG-1835 REV B
			ISSUED JJ	9/30/10	SCALE NONE SHEET 1 OF 1