

NOTES: UNLESS OTHERWISE SPECIFIED

REVISIONS			
REV	DESCRIPTION	DATE	APPROVED

- BATTERY CONFORMS TO THE REQUIREMENTS OF MIL-B-8565 AND MIL-B-8565/8, QUALIFIED PRODUCTS LISTED
- SEE DRAWING NO. CB-00263 AND PROCEDURE P-1000 FOR ASSEMBLY AND TEST INSTRUCTION. PROCEDURES AND ASSEMBLY DRAWINGS ARE FOR INTERNAL USE ONLY.
- BATTERY WEIGHT: 19.5 kg MAXIMUM.
- FOR DIMENSIONS NOT SHOWN, SEE MILITARY SPECIFICATION

5 CONNECTOR CONFORMS TO MIL-B-8565/8 PARA 3.5.5 AND TO DIMENSIONAL REQUIREMENTS FOR MATING CONNECTOR IN IEC STANDARD 952-3 TYPE C AND BRITISH STANDARD BS 6G 205 FORM C.

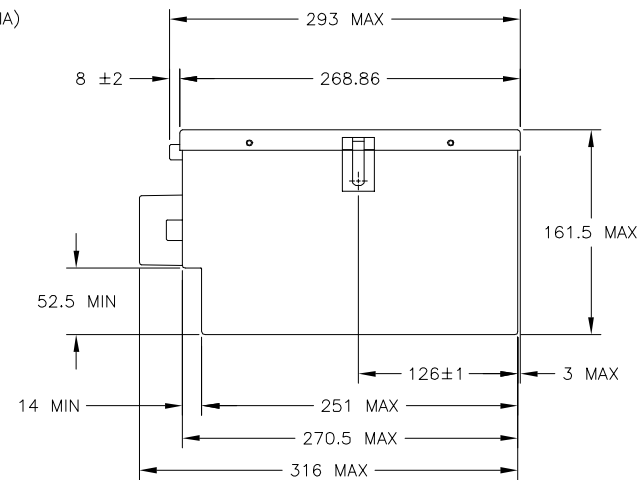
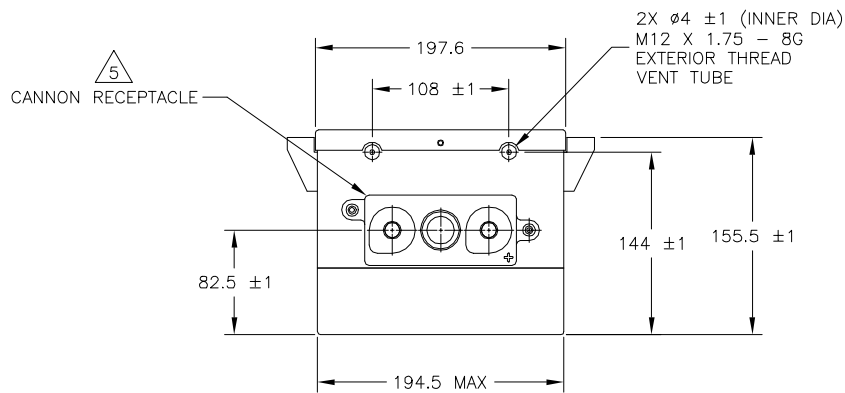
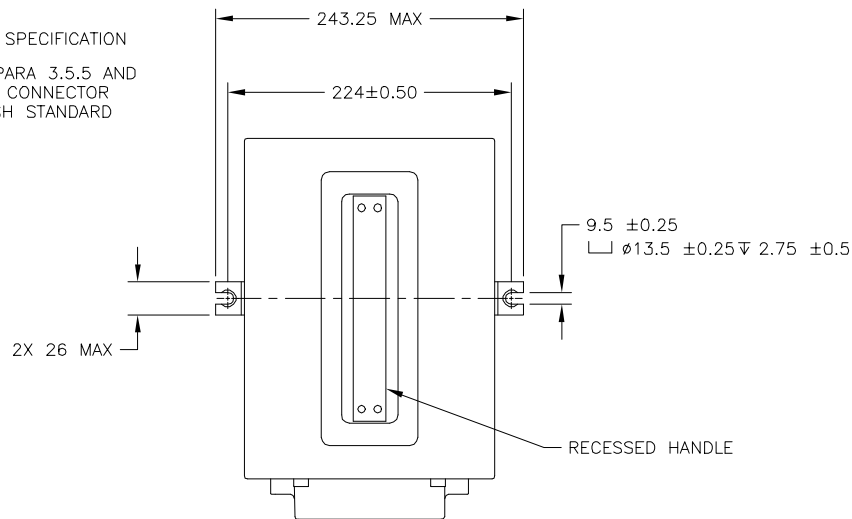

ENVELOPE DRAWING

QTY REQD		FSCM NO.	PART OR IDENTIFYING NO.	NOMENCLATURE OR DESCRIPTION	MATERIAL SPECIFICATION	ITEM NO.
PARTS LIST						
UNLESS OTHERWISE SPECIFIED DIMENSIONS ARE IN MILLIMETERS TOLERANCES ARE:		CONTRACT NO.		CONCORDE BATTERY CORPORATION 2009 SAN BERNARDINO RD, W. COVINA, CA 91790		
FRACTIONS	DECIMALS	ANGLES	APPROVALS	DATE	TITLE	
.XX ±			DRAWN B. PORTER	7/2/99	BATTERY, STORAGE, AIRCRAFT, 24 VOLT, 15 AH	
.XXX ±			CHECKED AMIII	8/5/99	SIZE	FSCM NO.
			APPROVED JBT	8/10/99	C	63017
FINISH	NONE		ISSUED DR	8/10/99	DWG. NO.	D8565/8-1
SIMILAR TO	ACT WT	CALC WT			SCALE	1/3
					SHEET	1 OF 1

ENGINEERING COPY 10AUG99