

NOTES: UNLESS OTHERWISE SPECIFIED

- BATTERY CONFORMS TO THE REQUIREMENTS OF MIL-B-8565 AND DOD-B-8565/7, QUALIFIED PRODUCTS LISTED
- SEE DRAWING NO. CB-00246 AND PROCEDURE P-1000 FOR ASSEMBLY AND TEST INSTRUCTION. PROCEDURES AND ASSEMBLY DRAWINGS ARE FOR INTERNAL USE ONLY.
- BATTERY WEIGHT: 29 kg MAXIMUM
- FOR DIMENSIONS NOT SHOWN, SEE MILITARY SPECIFICATION

REVISIONS			
REV	DESCRIPTION	DATE	APPROVED

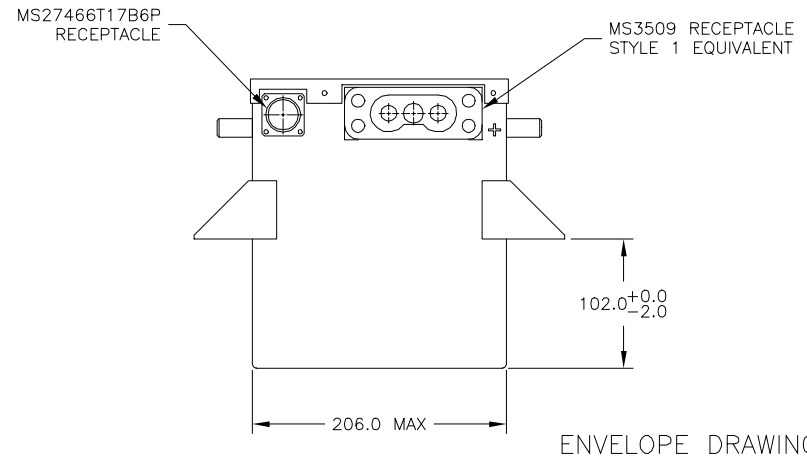
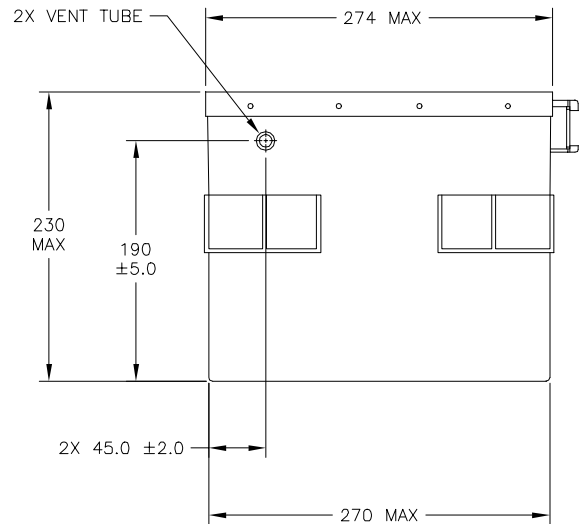
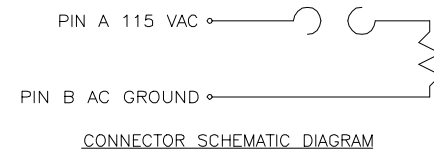
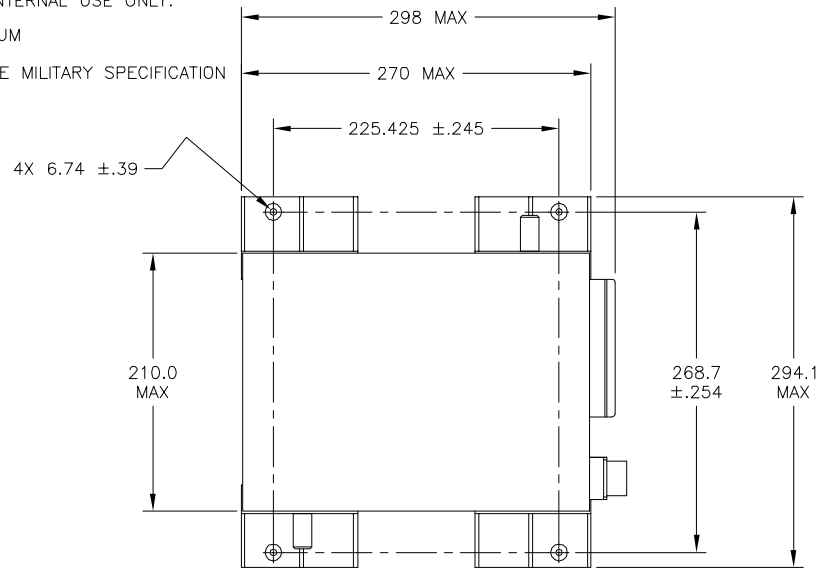

ENGINEERING COPY 06AUG99

QTY REQD		FSCM NO.	PART OR IDENTIFYING NO.	NOMENCLATURE OR DESCRIPTION	MATERIAL SPECIFICATION	ITEM NO.
PARTS LIST						
UNLESS OTHERWISE SPECIFIED DIMENSIONS ARE IN MILLIMETERS TOLERANCES ARE:				CONCORDE BATTERY CORPORATION		
FRACTIONS .XX ±				2009 SAN BERNARDINO RD, W. COVINA, CA 91790		
DECIMALS .XXX ±				TITLE BATTERY, STORAGE, AIRCRAFT,		
ANGLES				24 VOLT, 24 AH		
TREATMENT		NONE		APPROVALS	DATE	SIZE
FINISH		NONE		DRAWN B. PORTER	6/28/99	FSCM NO.
SIMILAR TO		NONE		CHECKED AMIII	8/2/99	DWG. NO.
ACT WT		CALC WT		APPROVED JBT	8/6/99	D8565/7-1
ISSUED DR		8/6/99		SCALE	1/3	REV
SHEET 1 OF 1						1