

NOTES: UNLESS OTHERWISE SPECIFIED

1. BATTERY CONFORMS TO THE REQUIREMENTS OF MIL-PRF-8565 AND MIL-B-8565/17
2. SEE DRAWING NO. CB-00308 AND PROCEDURE P-1000 FOR ASSEMBLY AND TEST INSTRUCTION. PROCEDURES AND ASSEMBLY DRAWINGS ARE FOR INTERNAL USE ONLY.
3. BATTERY MAXIMUM WEIGHT: 3.5 LBS (1.59 Kg)

4. GENERAL TOLERANCE: ± 0.065

| REVISIONS | | | |
|-----------|-----------------------|---------|----------|
| REV | DESCRIPTION | DATE | APPROVED |
| A | UPDATED TO NEW DESIGN | 11/3/05 | DV |

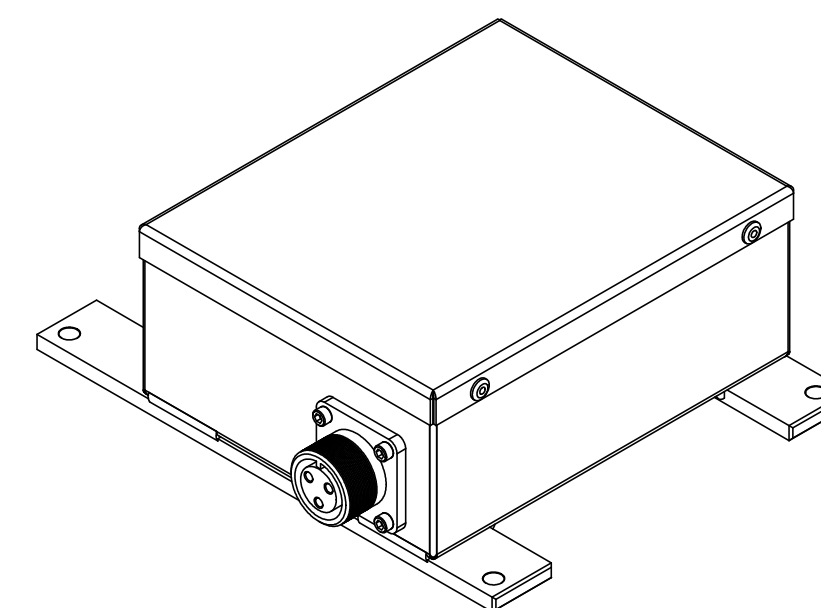
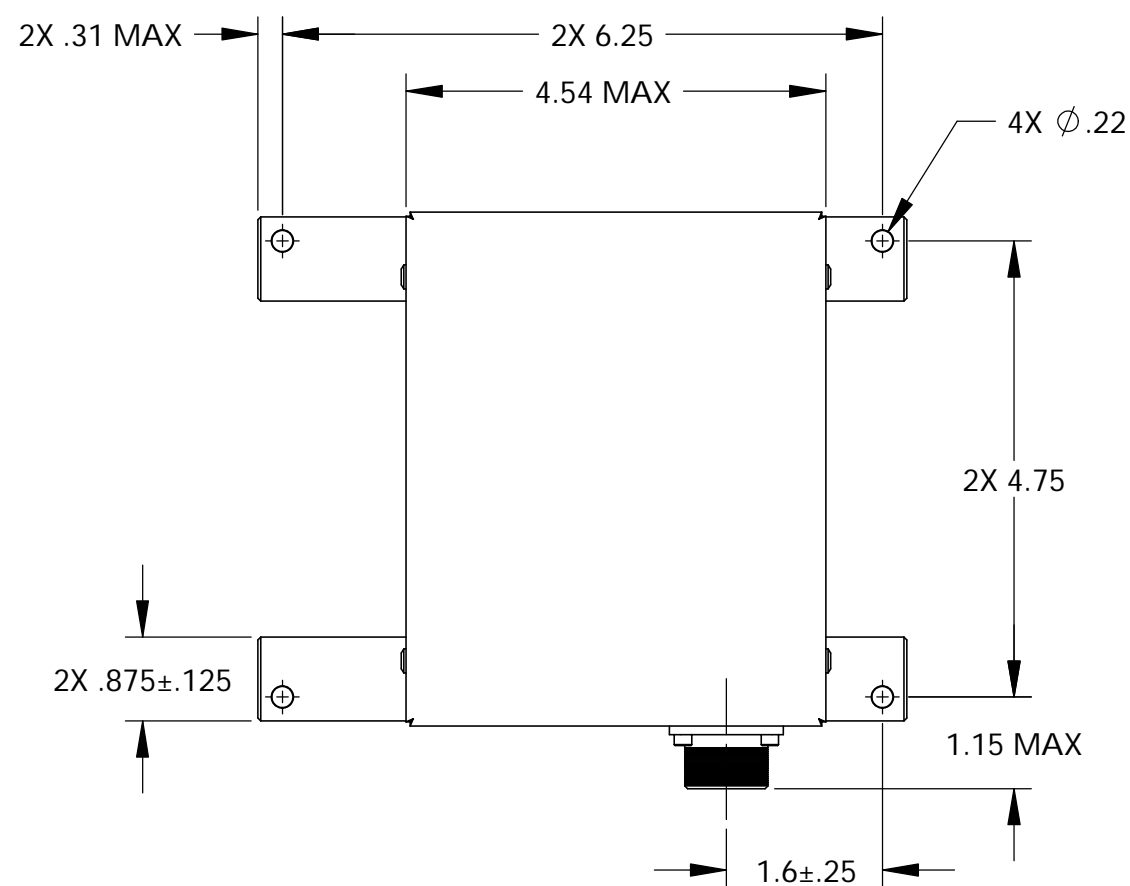

ISOMETRIC VIEW

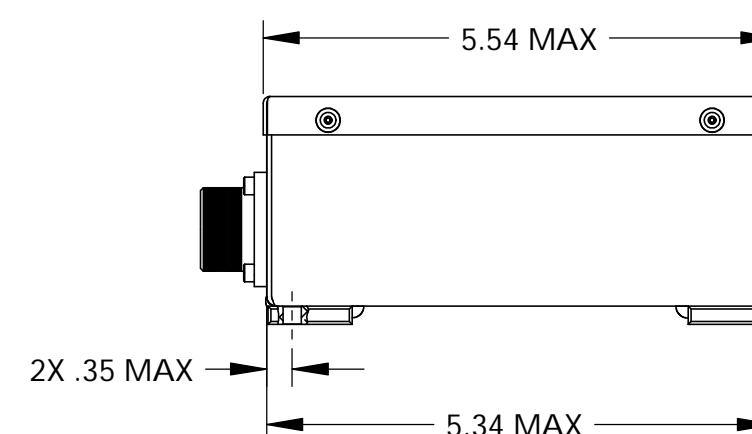
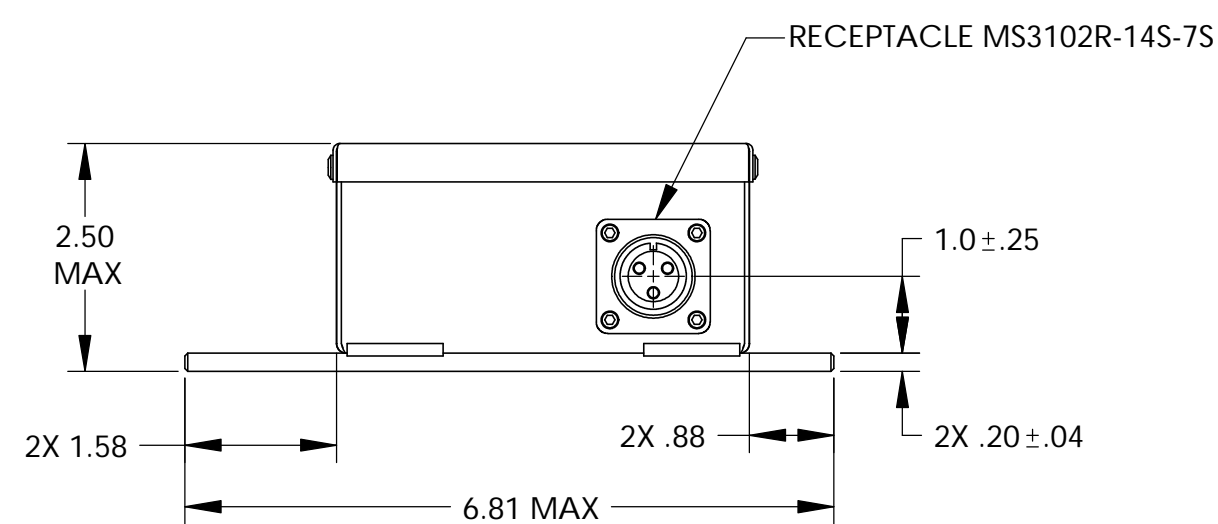

CONNECTION PIN IDENTIFICATION

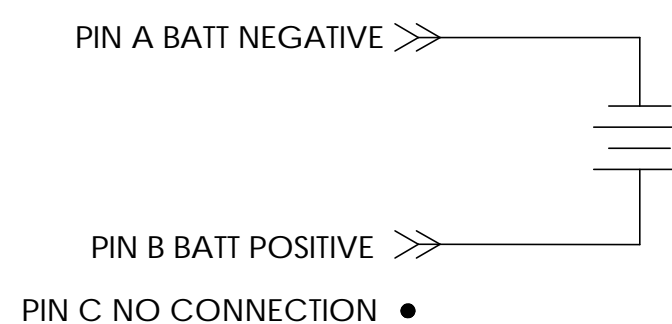

ENVELOPE DRAWING

| | | | | | |
|---|-----------------|---------------|-------------------|---|--|
| UNLESS OTHERWISE SPECIFIED DIMENSIONS ARE IN INCHES TOLERANCES ARE: | | CONTRACT NO. | | CONCORDE BATTERY CORPORATION 2009 SAN BERNARDINO RD, W. COVINA, CA 91790 | |
| FRACTIONS | DECIMALS | ANGLES | APPROVALS | DATE | TITLE |
| | .XX ± .XXX ± | 4 | DRAWN R.MURRIETTA | 2/07/05 | BATTERY, STORAGE, AIRCRAFT, 24 VOLT, 1/3 AH |
| TREATMENT | NONE | CHECKED AMIII | 3/30/05 | SIZE C | CAGE CODE 63017 |
| FINISH | NONE | APPROVED DV | 3/31/05 | DWG NO. D8565/17-1 | REV A |
| SIMILAR TO | CALC WT | ISSUED NS | 11/7/05 | SCALE 1:1 | SHEET 1 OF 1 |