

NOTES: UNLESS OTHERWISE SPECIFIED

- BATTERY CONFORMS TO THE REQUIREMENTS OF MIL-PRF-8565 AND MIL-PRF-8565/14, QUALIFIED PRODUCTS LISTED.
- SEE DRAWING NO. CB-00216 AND PROCEDURE P-1000 FOR ASSEMBLY AND TEST INSTRUCTION. PROCEDURES AND ASSEMBLY DRAWINGS ARE FOR INTERNAL USE ONLY.
- BATTERY WEIGHT: 18.7kg MAXIMUM
- FOR DIMENSIONS NOT SHOWN, SEE MILITARY SPECIFICATIONS.

| REVISIONS | | | |
|-----------|---------------------------------|---------|----------|
| REV | DESCRIPTION | DATE | APPROVED |
| A | UPDATED NOTE 1, FIXED CAGE CODE | 1/31/03 | JBT |
| B | ADDED CG | 5/20/04 | JBT |

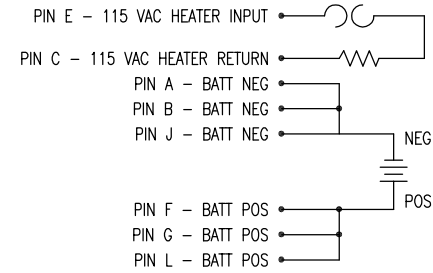
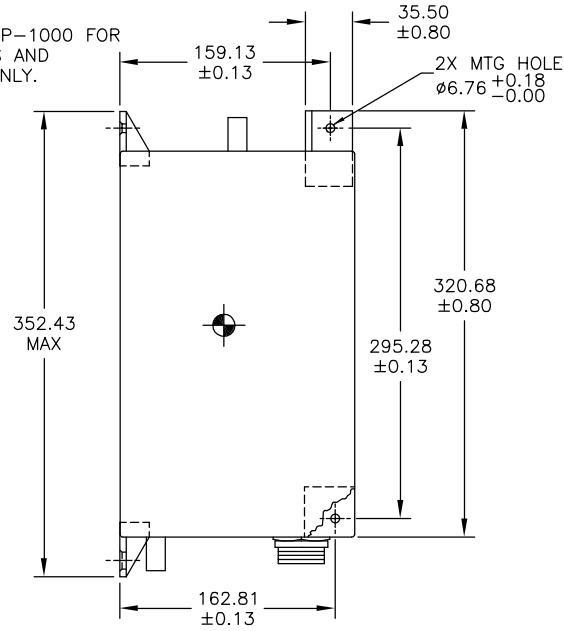

CONNECTOR SCHEMATIC DIAGRAM

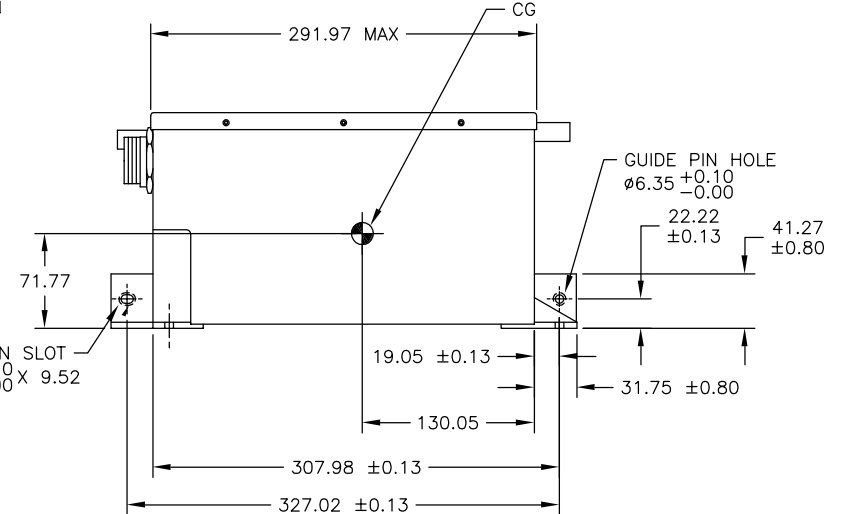
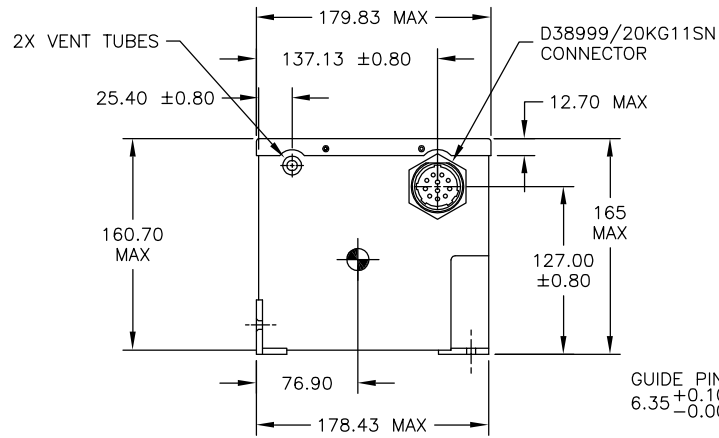

ENVELOPE DRAWING

| QTY REQD | CAGE CODE | PART OR IDENTIFYING NO. | NOMENCLATURE OR DESCRIPTION | MATERIAL SPECIFICATION | ITEM NO. |
|---|-----------|-------------------------|--|------------------------|----------|
| PARTS LIST | | | | | |
| UNLESS OTHERWISE SPECIFIED DIMENSIONS ARE IN INCHES TOLERANCES ARE: | | | CONTRACT NO. | | |
| FRACTIONS DECIMALS ANGLES | | | CONCORDE BATTERY CORPORATION | | |
| ± .XX ± ± | | | 2009 SAN BERNARDINO RD, W. COVINA, CA 91790 | | |
| ± .XXX ± | | | TITLE BATTERY, STORAGE, AIRCRAFT, 24 VOLT, 15 AH | | |
| TREATMENT | NONE | CHECKED | AMIII | DATE | 8/6/99 |
| FINISH | NONE | APPROVED | JBT | DATE | 8/10/99 |
| SIMILAR TO | ACT WT | CALC WT | ISSUED | AT | 5/20/04 |
| SCALE | | 1=3 | | SHEET 1 OF 1 | |