

NOTES: UNLESS OTHERWISE SPECIFIED

- BATTERY CONFORMS TO THE REQUIREMENTS OF MIL-B-8565/13
- SEE DRAWING NUMBER CB-00213 AND PRODUCTION INSTRUCTION PI-1000 FOR ASSEMBLY AND TEST INSTRUCTION. PRODUCTION INSTRUCTIONS AND ASSEMBLY DRAWINGS ARE FOR INTERNAL USE ONLY.

REVISIONS			
REV	DESCRIPTION	DATE	APPROVED
A	REV AND REDRAWN WAS D8565/INS	7/23/98	JBT

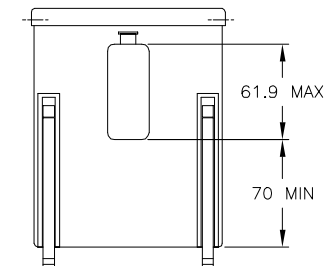
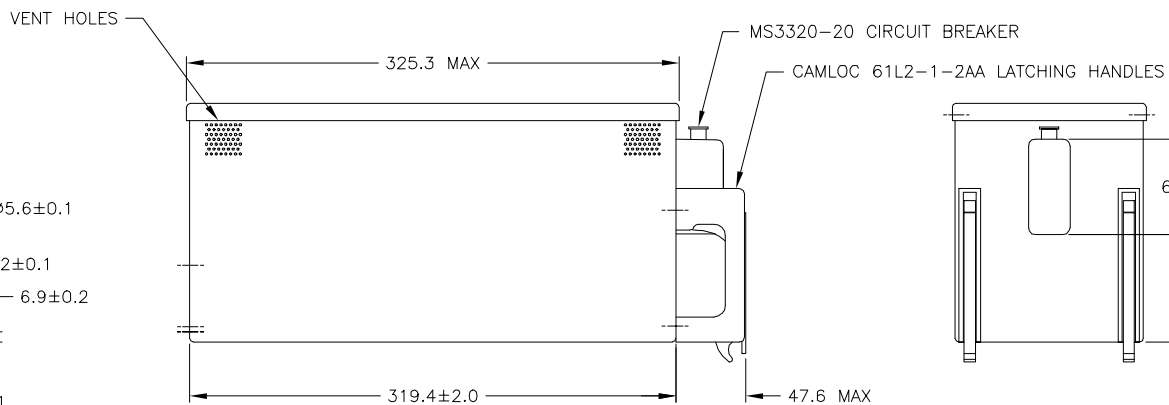
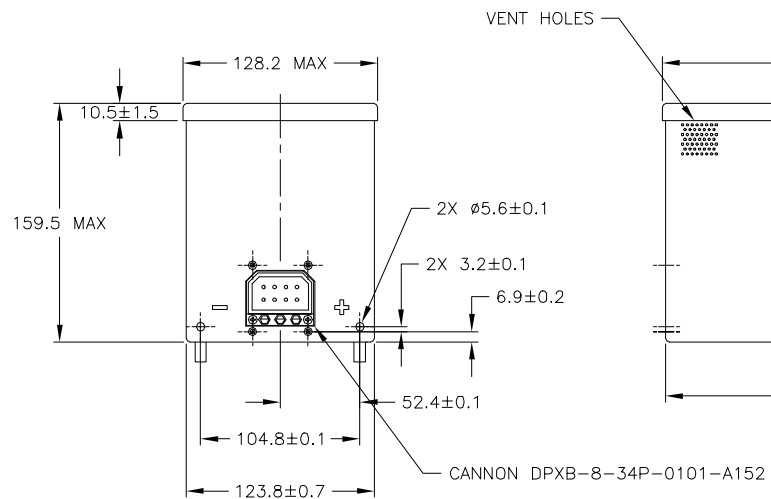
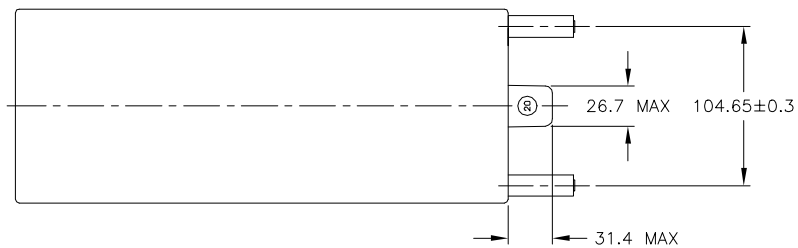

ENVELOPE DRAWING

ENGINEERING COPY 28JUL98

QTY REQD	FSCM NO.	PART OR IDENTIFYING NO.	NOMENCLATURE OR DESCRIPTION	MATERIAL SPECIFICATION	ITEM NO.
PARTS LIST					
UNLESS OTHERWISE SPECIFIED DIMENSIONS ARE IN MILLIMETERS TOLERANCES ARE:		CONTRACT NO.		CONCORDE BATTERY CORPORATION 2009 SAN BERNARDINO RD, W. COVINA, CA 91790	
FRACTIONS	DECIMALS	ANGLES	APPROVALS	DATE	TITLE
.XX ±	.XXX ±		DRAWN TORRES J.	5/18/93	BATTERY, STORAGE, AIRCRAFT, 24 VOLT, 10 AH
TREATMENT	NONE	CHECKED	JR	9/2/93	SIZE
FINISH	NONE	APPROVED	GH	9/2/93	FSCM NO. 63017
SIMILAR TO	ACT WT	ISSUED	MK	7/24/98	DWG. NO. D8565/13-1
	CALC WT				SCALE NONE
					SHEET 1 OF 1
					REV A