

NOTES: UNLESS OTHERWISE SPECIFIED

- BATTERY CONFORMS TO THE REQUIREMENTS OF MIL-B-8565 AND MIL-B-8565/11, QUALIFIED PRODUCTS LISTED
- SEE DRAWING NO. CB-00172 AND PROCEDURE P-1000 FOR ASSEMBLY AND TEST INSTRUCTION. PROCEDURE AND ASSEMBLY DRAWINGS ARE FOR INTERNAL USE ONLY.
- BATTERY WEIGHT: 15.8kg MAXIMUM
- FOR DIMENSIONS NOT SHOWN, SEE MILITARY SPECIFICATION

REVISIONS			
REV	DESCRIPTION	DATE	APPROVED

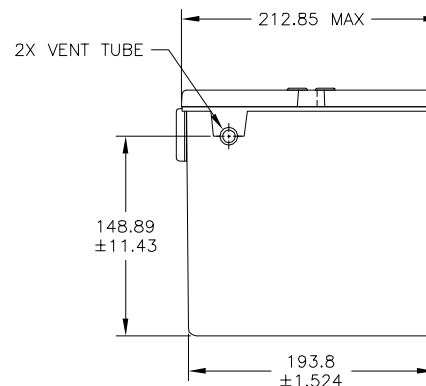
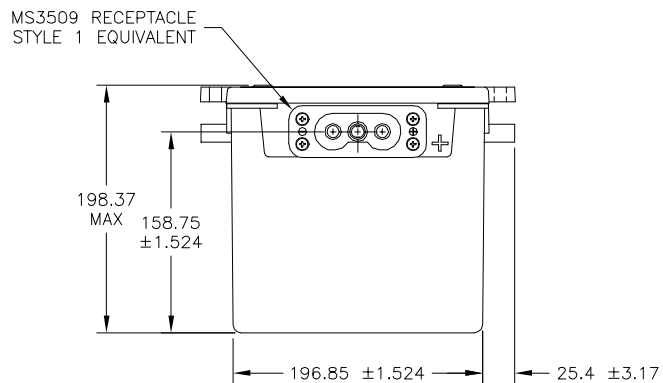
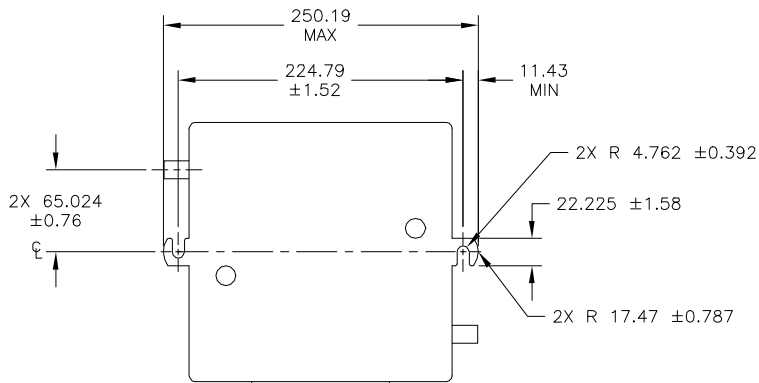

ENVELOPE DRAWING

QTY REQD	FSCM NO.	PART OR IDENTIFYING NO.	NOMENCLATURE OR DESCRIPTION	MATERIAL SPECIFICATION	ITEM NO.
PARTS LIST					
UNLESS OTHERWISE SPECIFIED DIMENSIONS ARE IN MILLIMETERS TOLERANCES ARE:			CONTRACT NO.		
FRACTIONS	DECIMALS	ANGLES	APPROVALS	DATE	TITLE
.XX ±	.XXX ±		DRAWN R. ROWE	8/06/99	CONCORDE BATTERY CORPORATION 2009 SAN BERNARDINO RD, W. COVINA, CA 91790 BATTERY, STORAGE, AIRCRAFT, 24 VOLT, 10 AH
			CHECKED AMIII	8/6/99	
TREATMENT	NONE		APPROVED JBT	8/10/99	SIZE FSCM NO. DWG. NO. REV
FINISH	NONE		ISSUED DR	8/10/99	C 63017 D8565/11-1
SIMILAR TO	ACT WT	DLG WT			SCALE 1=3 SHEET 1 OF 1

ENGINEERING COPY 10AUG99