

NOTES: UNLESS OTHERWISE SPECIFIED

1. SEE DRAWING NO. CB-00281 AND PROCEDURE P-1000 FOR ASSEMBLY AND TEST INSTRUCTION. PROCEDURES AND ASSEMBLY DRAWING ARE FOR INTERNAL USE ONLY.
2. ALL TESTING IS PERFORMED IAW BATTERY COUNCIL INTERNATIONAL STANDARDS.
3. ALL DIMENSIONS ARE IN INCHES [MM]
4. TERMINAL HARDWARE KIT PROVIDED, PART NUMBER 6923

REVISIONS			
REV	DESCRIPTION	DATE	APPROVED
A	CHANGED HANDLE DIRECTION	2/26/07	JBT
B	REVISED COVER & HANDLE	11/6/07	JBT

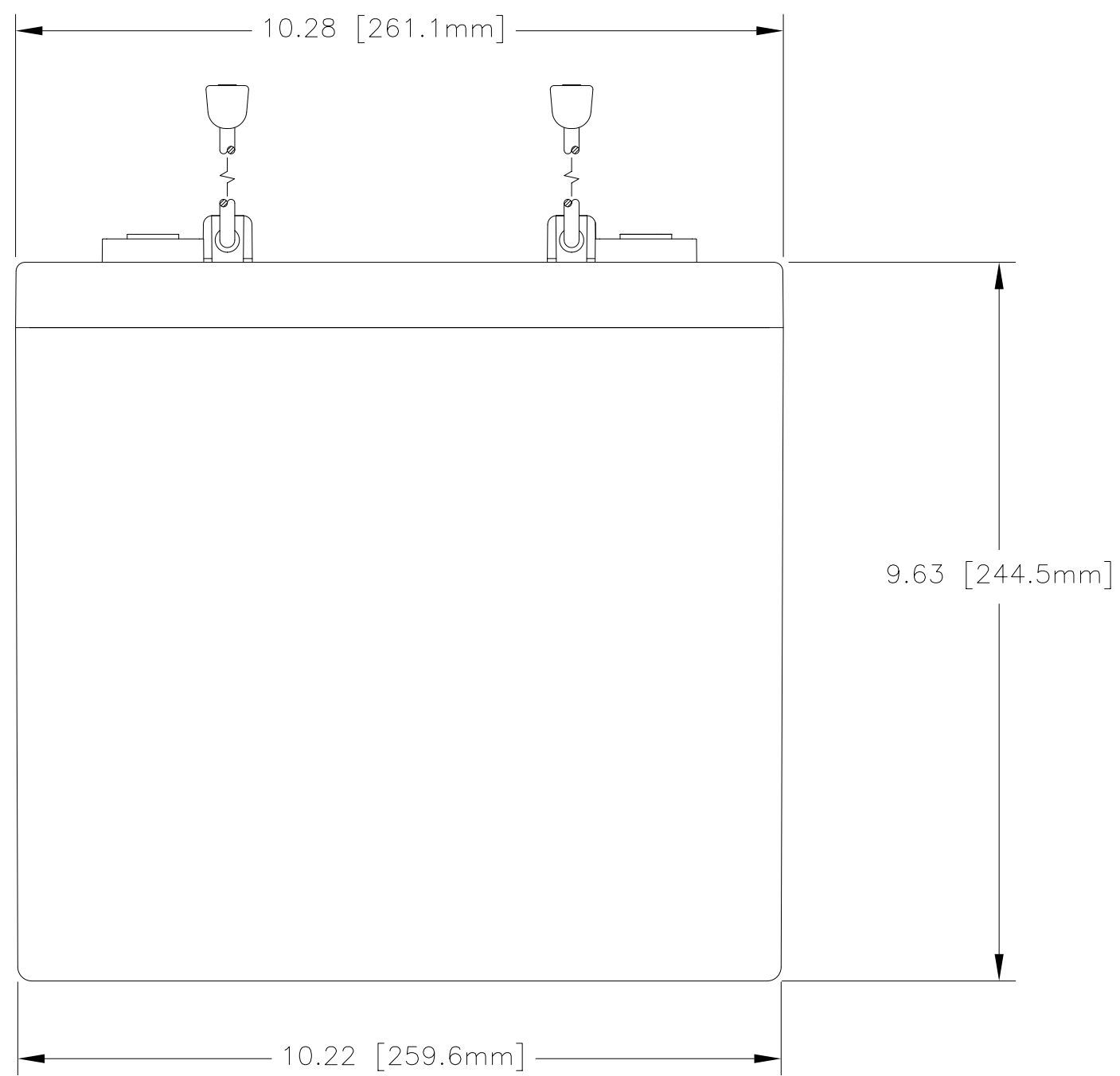
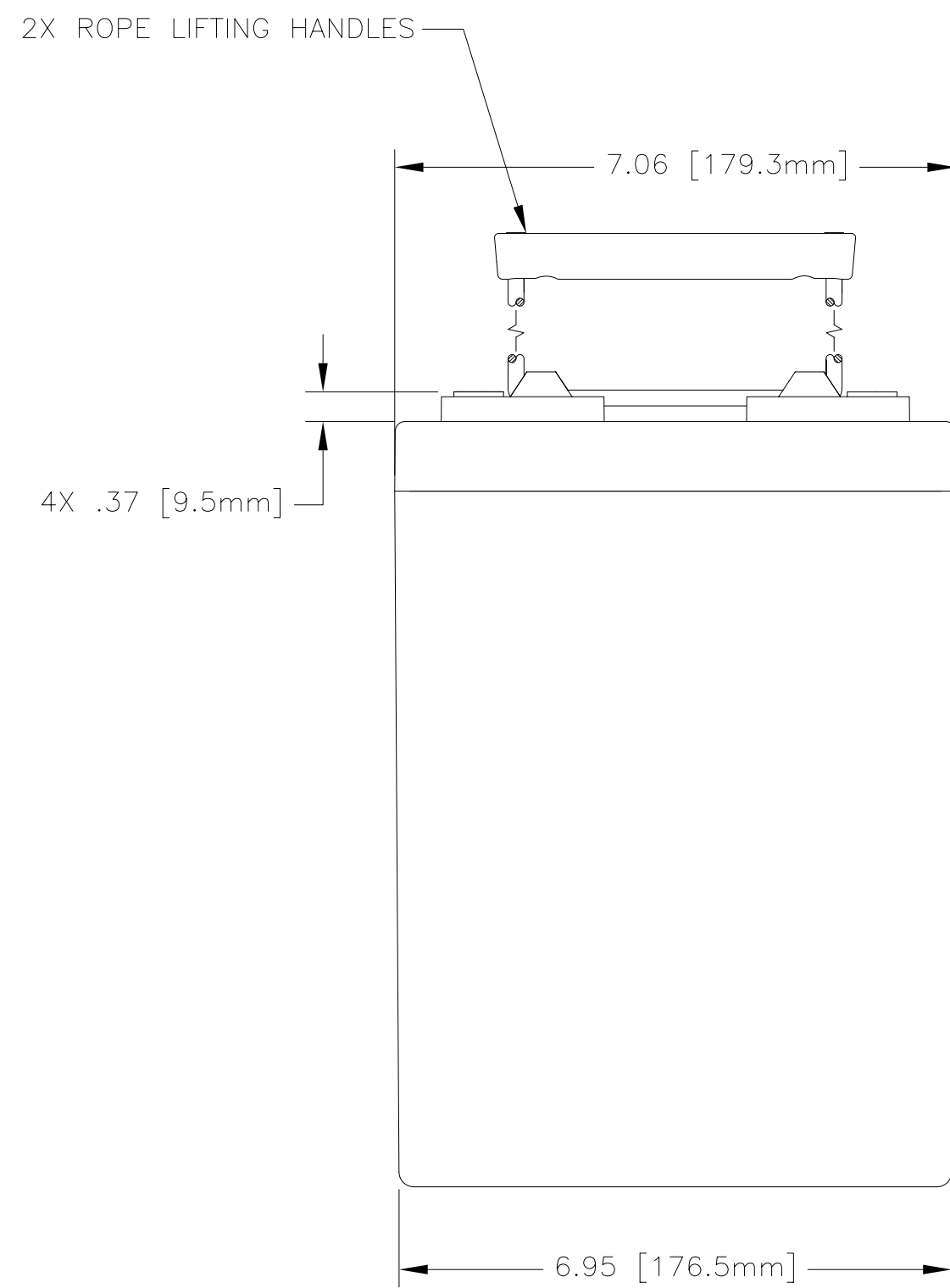
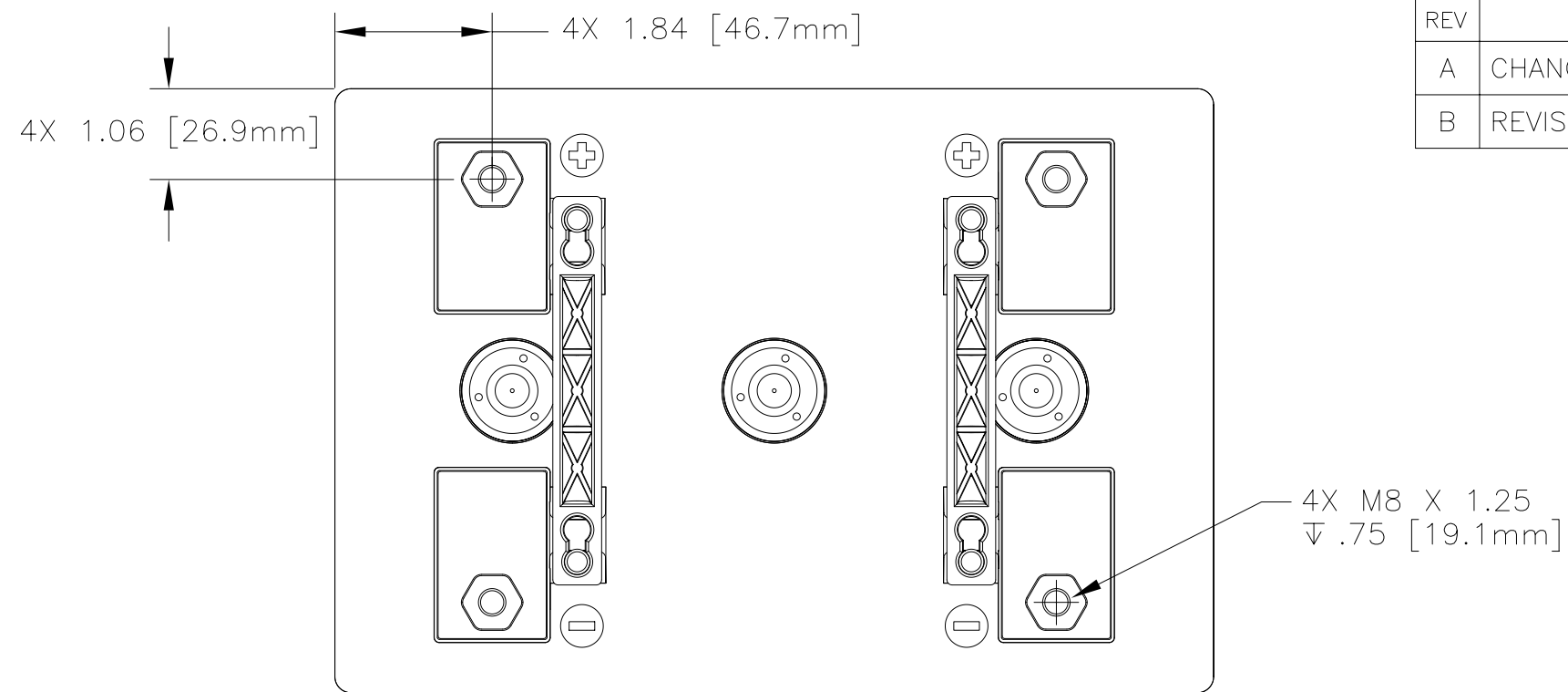

CAPACITY RATINGS	
PART NUMBER	AGM-2660T
NOMINAL WEIGHT	69 LBS [31.3 KG]
AMPERE HOUR CAPACITY @ 20 HOUR 1.75 VOLTS/CELL @ 77°F (25° C)	660 AH
MINUTES OF DISCHARGE @ 25 AMPS 1.75 VOLTS/CELL @ 77°F (25° C)	492 MIN

ENVELOPE DRAWING

QTY REQD	CAGE CODE	PART OR IDENTIFYING NO.	NOMENCLATURE OR DESCRIPTION	MATERIAL SPECIFICATION	ITEM NO.
PARTS LIST					
UNLESS OTHERWISE SPECIFIED DIMENSIONS ARE IN INCHES TOLERANCES ARE:			CONTRACT NO.		
FRACTIONS DECIMALS ANGLES			APPROVALS DATE		
± 1/32 .XX ± .12 ± 1°			DRAWN D. AYALA 12/15/06		
.XXX ± .060			CHECKED AMIII 1/9/07		
TREATMENT NONE			APPROVED JBT 1/10/07		
FINISH NONE			ISSUED NS 11/28/07		
SIMILAR TO N/A			SCALE 1/2		
ACT WT N/A			SHEET 1 OF 1		
CALC WT N/A			TITLED		
			CONCORDE BATTERY CORPORATION		
			2009 SAN BERNARDINO RD, W. COVINA, CA 91790		
			BATTERY, 2 VOLT, AGM-2660T		
			CAGE CODE 63017		
			DWG NO. AGM-2660T		
			REV B		