

NOTES: UNLESS OTHERWISE SPECIFIED

1. SEE DRAWING NO. CB-00295 AND PROCEDURE P-1000 FOR ASSEMBLY AND TEST INSTRUCTION. PROCEDURES AND ASSEMBLY DRAWINGS ARE FOR INTERNAL USE ONLY.
2. ALL TESTING ARE IAW BATTERY COUNCIL INTERNATIONAL STANDARDS.
3. ALL DIMENSIONS ARE IN INCHES [MM].

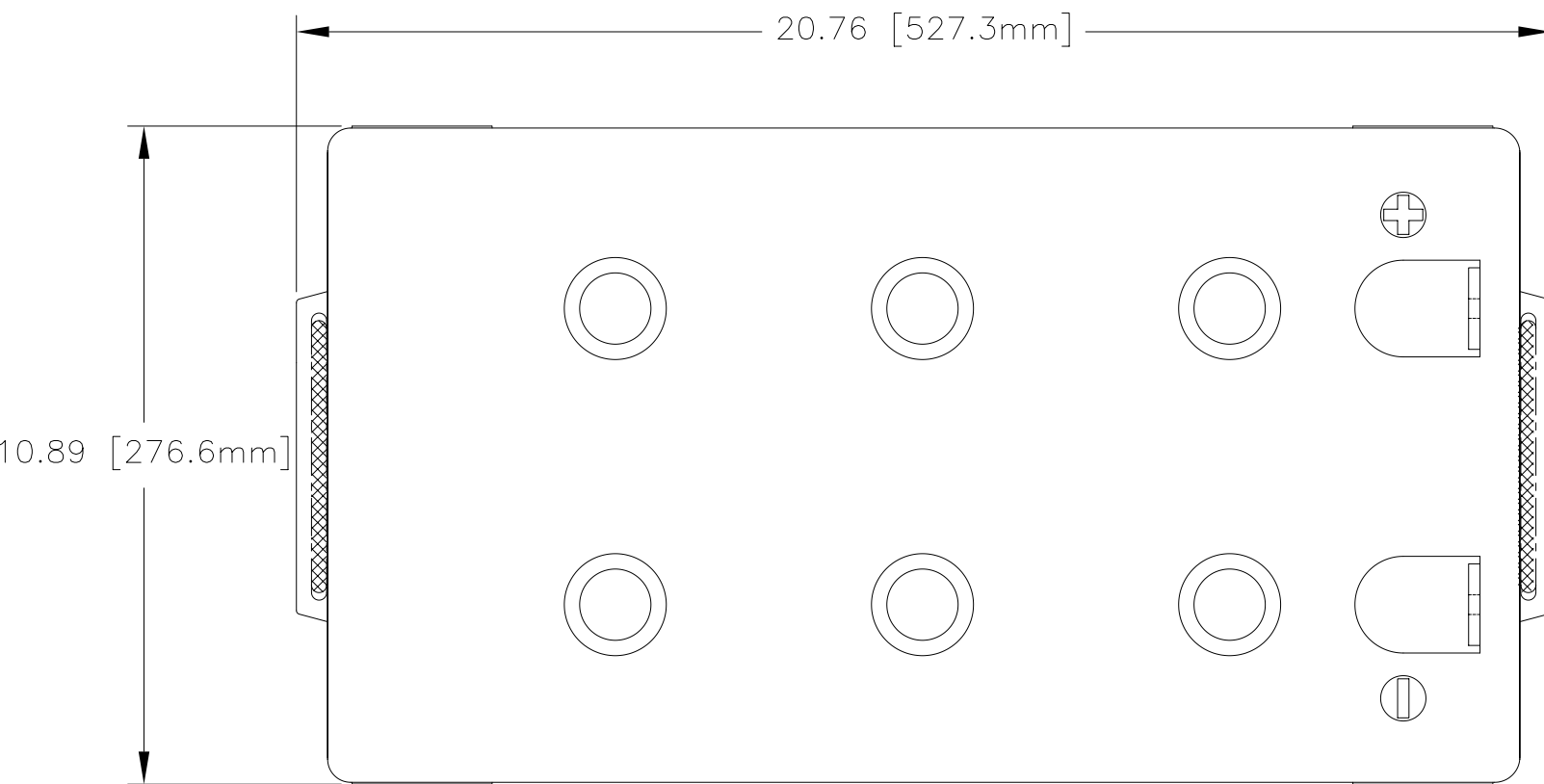

AGM-12255 OPTIONS:

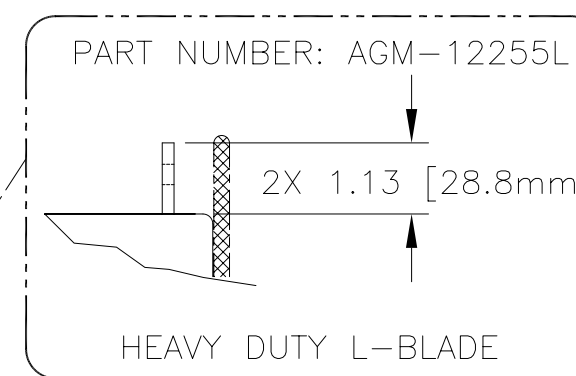

NOTE: SEE OPTIONS LISTED

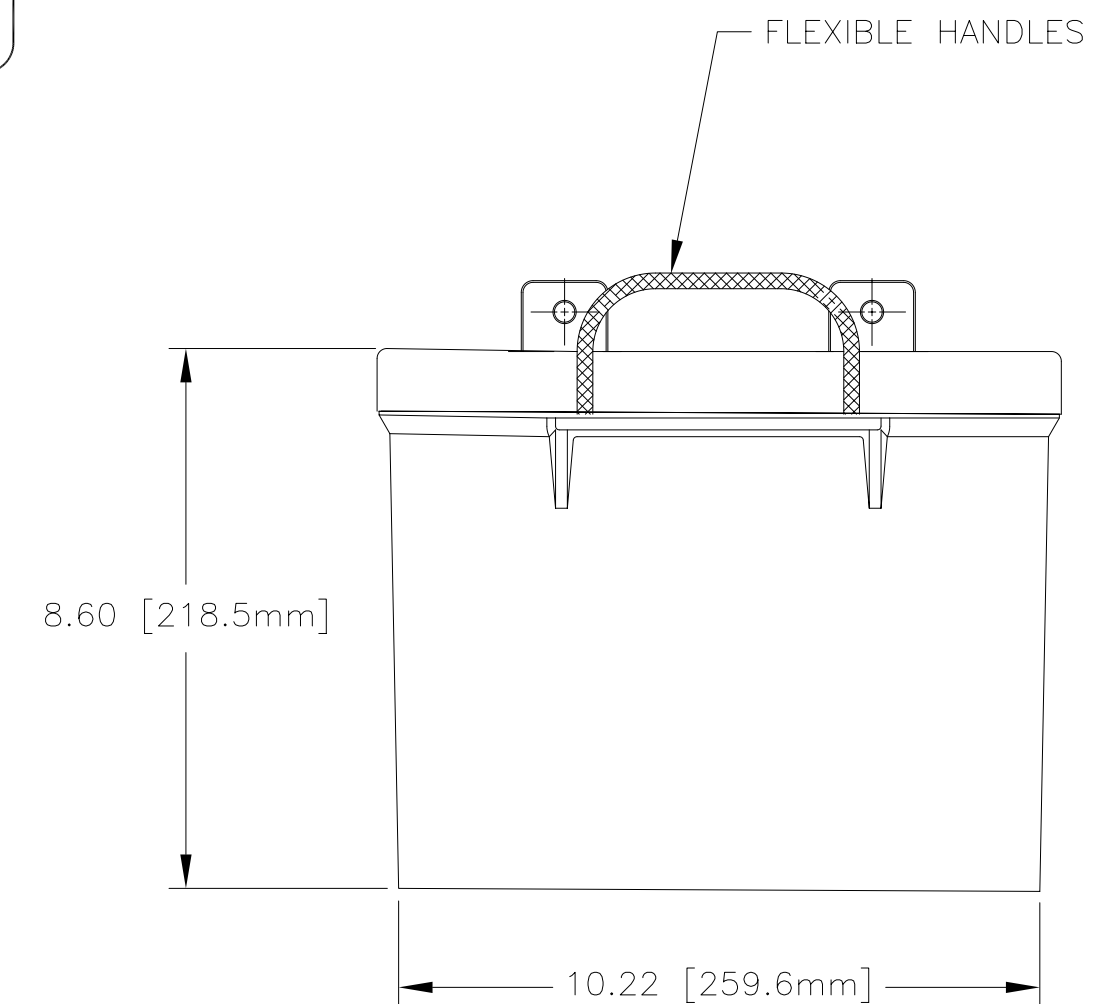
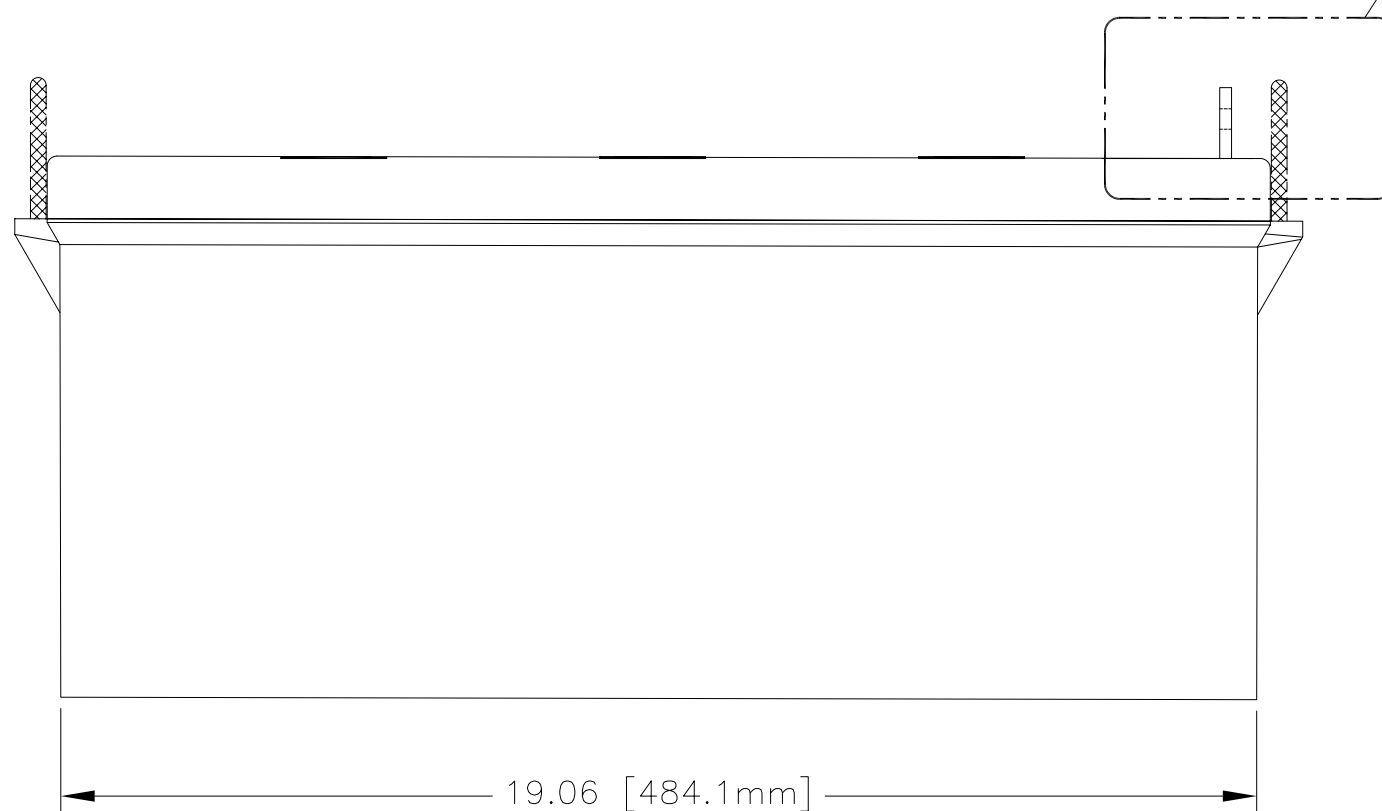

REVISIONS			
REV	DESCRIPTION	DATE	APPROVED
A	REDESIGNED CONTAINER, COVER	4/2/02	JBT
B	1.13 WAS 1.05	2/19/04	JBT

ENVELOPE DRAWING

CAPACITY RATINGS	
PART NUMBER	AGM-12255
NOMINAL WEIGHT	162 LBS[73.6 KG]
AMPERE HOUR CAPACITY @ 20 HOUR 1.75 VOLTS/CELL @ 77°F (25° C)	255 AH
MINUTES OF DISCHARGE @ 25 AMPS 1.75 VOLTS/CELL @ 77°F (25° C)	475 MIN

QTY REQD	CAGE CODE	PART OR IDENTIFYING NO.	NOMENCLATURE OR DESCRIPTION	MATERIAL SPECIFICATION	ITEM NO.
PARTS LIST					
UNLESS OTHERWISE SPECIFIED DIMENSIONS ARE IN INCHES. TOLERANCES ARE: FRACTIONS DECIMALS ANGLES ±1/32 .XX ± .06 ±1° .XXX ± .030			CONCORDE BATTERY CORPORATION 2009 SAN BERNARDINO RD, W. COVINA, CA 91790		
TREATMENT NONE			BATTERY, 12 VOLT, AGM-12255		
FINISH NONE			AGM-12255		
SIMILAR TO N/A			AGM-12255		
ACT WT N/A			AGM-12255		
CALC WT N/A			AGM-12255		
ISSUED AT			AGM-12255		
SCALE NONE			AGM-12255		
SHEET 1 OF 1			AGM-12255		

ENGINEERING COPY 02MAR04