

NOTES: UNLESS OTHERWISE SPECIFIED

1. SEE DRAWING NO. CB-00285 AND PROCEDURE P-1000 FOR ASSEMBLY AND TEST INSTRUCTION. PROCEDURES AND ASSEMBLY DRAWINGS ARE FOR INTERNAL USE ONLY.
2. ALL TESTING ARE IAW BATTERY COUNCIL INTERNATIONAL STANDARDS.
3. ALL DIMENSIONS ARE IN INCHES [MM].

REVISIONS			
REV	DESCRIPTION	DATE	APPROVED
A	REVISED CAPACITY TABLE	3/15/00	JBT
B	METRICIZED INSERT AND REV. ASSY NO. WAS: CB-00279	12/23/00	JBT
C	REMOVED SIDE HOLD-DOWNS	6/10/03	JBT

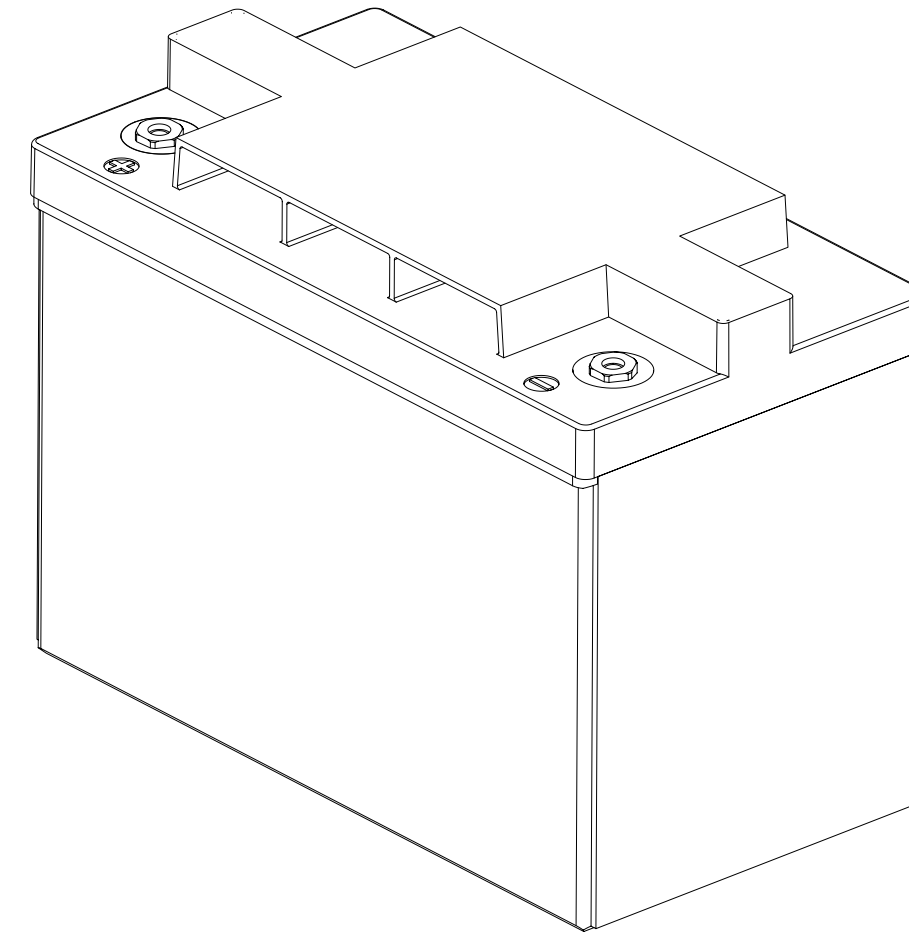
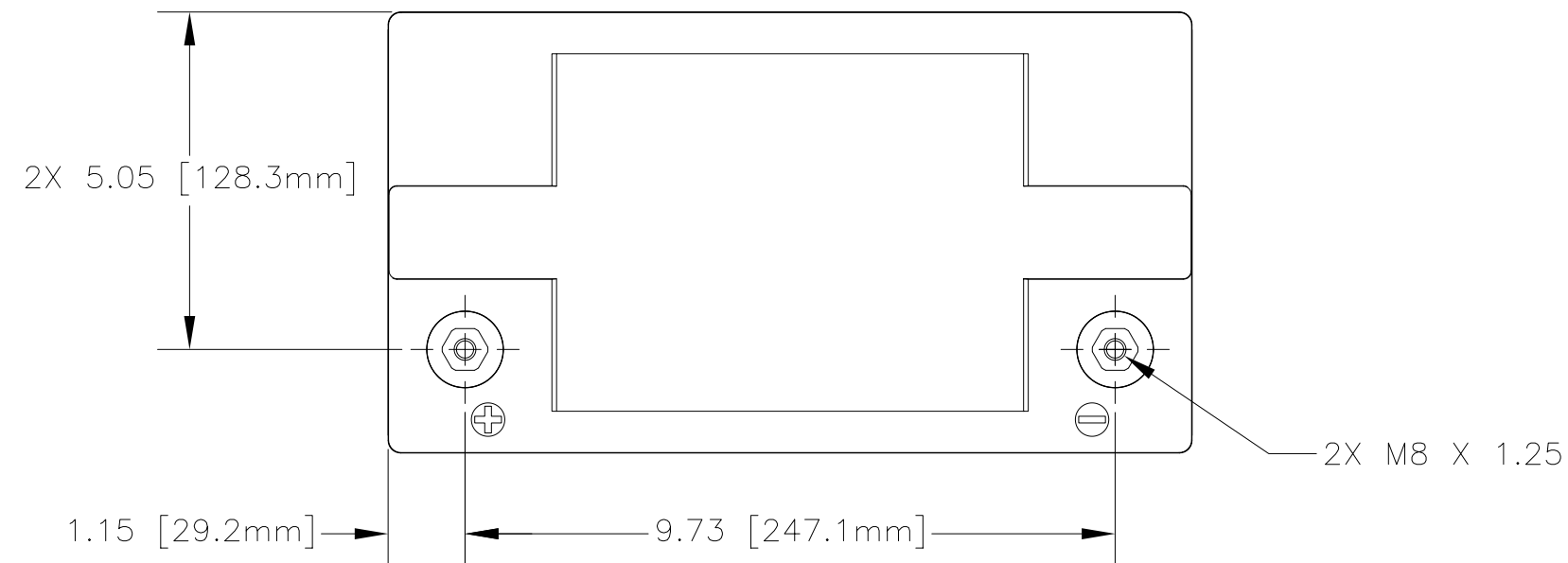

REFERENCE VIEW

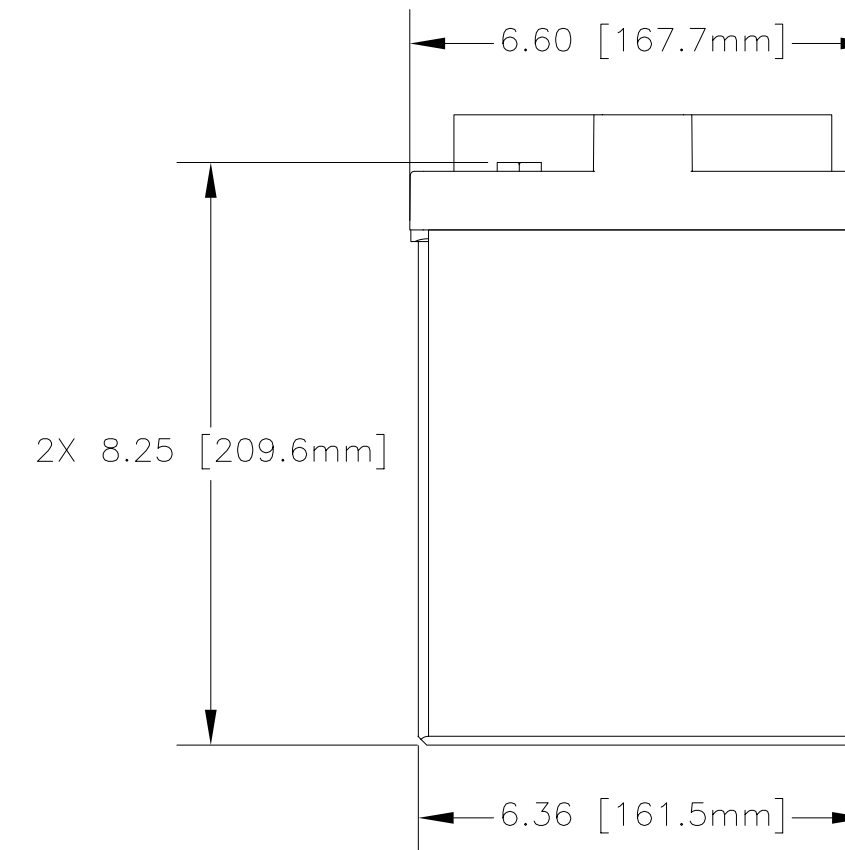
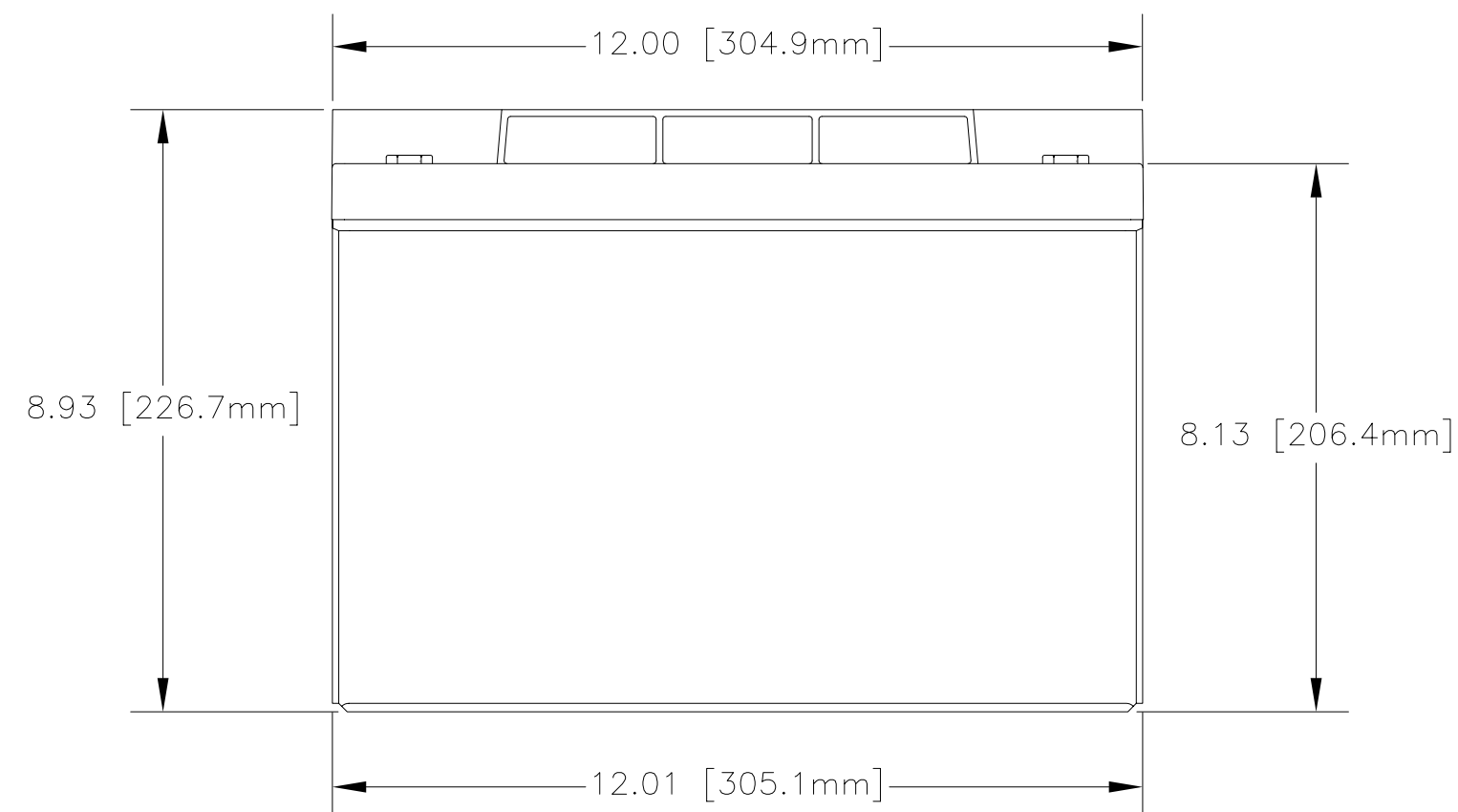

CAPACITY RATINGS	
PART NUMBER	AGM-12100T
NOMINAL WEIGHT	65 LBS [29.5 KG]
AMPERE HOUR CAPACITY @ 20 HOUR 1.75 VOLTS/CELL @ 77°F (25°C)	100 AH
MINUTES OF DISCHARGE @ 25 AMPS 1.75 VOLTS/CELL @ 77°F (25°C)	186 MIN

ENVELOPE DRAWING

QTY REQD	CAGE CODE	PART OR IDENTIFYING NO.	NOMENCLATURE OR DESCRIPTION	MATERIAL SPECIFICATION	ITEM NO.
PARTS LIST					
UNLESS OTHERWISE SPECIFIED DIMENSIONS ARE IN INCHES TOLERANCES ARE: FRACTIONS DECIMALS ANGLES ± 1/32 .XX ± .06 ± 1° .XXX ± .030			CONCORDE BATTERY CORPORATION 2009 SAN BERNARDINO RD, W. COVINA, CA 91790		
TREATMENT NONE		APPROVALS		DATE	
FINISH NONE		DRAWN ELH		3/1/00	
SIMILAR TO NA		CHECKED S.VALDEZ		3/1/00	
ACT WT NA		APPROVED JBT		3/4/00	
CALC WT NA		ISSUED AT		6/13/03	
TITLE			BATTERY, 12 VOLT, AGM-12100T		
SIZE	CAGE CODE	DWG NO.	REV		
C	63017	AGM-12100T	C		
SCALE NONE			SHEET 1 OF 1		

ENGINEERING COPY 13JUN03