



# RG-385

## 24V Main Aircraft Battery

### Approved for Installation on the F-5

Recombinant Gas - The RG<sup>®</sup> Series are low resistance, valve regulated lead acid (VRLA) batteries. U.S. and Armed Forces worldwide have found reliability and superior performance with Concorde Valve Regulated Sealed Lead Acid Batteries (VRSLA / VRLA / SLAB).

- Reliable essential power in the event of a generator failure
- Maintenance free – no addition of electrolyte or water ever required
- Direct replacement for maintenance intensive Nickel Cadmium batteries
- Factory tested to assure airworthiness
- The original AGM (Absorbent Glass Mat) battery designed for the US Military
- Improved aircraft readiness - shipped fully charged and ready to install
- RG<sup>®</sup> Series batteries ship Hazmat Exempt

| MAIN AIRCRAFT BATTERY                                   | Volts   | C1 Rate | IEC Rated for Peak Power (IPP) & 15 second Power Rating (IPR) |        |                  |        |                    |        | Maximum Weight    |
|---|---------|---------|---|--------|------------------|--------|--------------------|--------|-------------------|
|   |         |         | IPP IPR   |        | IPP IPR          |        | IPP IPR            |        |                   |
|   |         |         | At 23° C (74° F)  |        | At -18° C (0° F) |        | At -30° C (-22° F) |        |                   |
| <b>RG-385</b>   | 24 VOLT | 13 AH   | 1561 Ah   | 601 Ah | 1275 Ah          | 466 Ah | 1514 Ah            | 335 Ah | 34.0 LB / 15.4 KG |
| Rated in accordance with International Standard 60952-1 |         |         |   |        |                  |        |                    |        |                   |

Specifications subject to change without notice

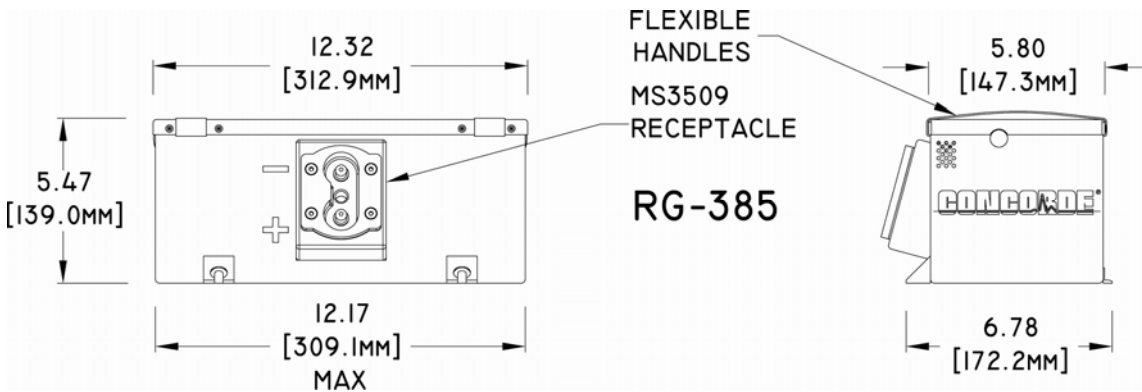

**Concorde Battery Corporation** is the largest supplier of Original Equipment VRLA Batteries to manufacturers including Agusta, American Champion, American Eurocopter, Aviat, Bell, Bombardier / Learjet, Cessna, Cirrus, Commander, Dassault, Diamond, Enstrom Helicopter, Erickson Air Crane, Extra, Gippsland, Grobe, Gulfstream, Hawker Beechcraft, JetPROP, Liberty, Lockheed Martin, Maule, Mooney, Northrop Grumman, Piaggio, Pilatus, Piper Aircraft, Robinson Helicopter, Scaled Composites, Schweizer, Sikorsky, Slingsby Aviation, Socata, Zlin and more. Over 50 Concorde batteries and accessories are **FAA Parts Manufacturing Approved & TSO Authorized** for installation on more than 1,000 aircraft models.



Concorde Battery Corporation  
 2009 San Bernardino Road  
 West Covina, CA, 91790, USA  
 Phone 626-813-1234 | Fax 626-813-1235  
 Email: customer-service@concordebattery.com  
 www.concordebattery.com  
 ISO 9001:2000 and AS9100B