

RG-131

12 AH, 1/2 ATR SHORT, RACK MOUNTABLE

TSO APPROVED



24 Volt Emergency Aircraft Batteries for Back Up – Avionics – INS – FADEC and more

RG-131 can be used for any custom application meeting conditions of the Technical Standard Order. Avionics Battery for INS, lighting, standby, emergency power. Protects and extends the life of other avionics and are charged directly from the DC bus with no need for a dedicated charger. This results in a high inrush current which extends battery life with fast recovery time from discharge. With the battery connected directly to the bus, transient spikes in the DC power are absorbed by the battery.

RG-131

- Maximum weight 31.0 LB / 14.1 KG
- Rated Capacity C₁ 12 AH
- Plug and Play Cannon Receptacle DPXB-34P-0101-A152 or Equal
- Circuit Breaker MS 3220-20
- Camloc 61L2-1-2A Latching Handles
- Self regulating on charge
- Takes only the current required to maintain a full charge
- Certified Nickel Cadmium Replacement
- RG[®] Series Batteries - Valve Regulated Sealed Lead Acid (VRSLA)
- Maintenance free; no addition of electrolyte or water required
- Shipped fully charged and ready to install
- RG[®] Series Batteries ship Hazmat Exempt

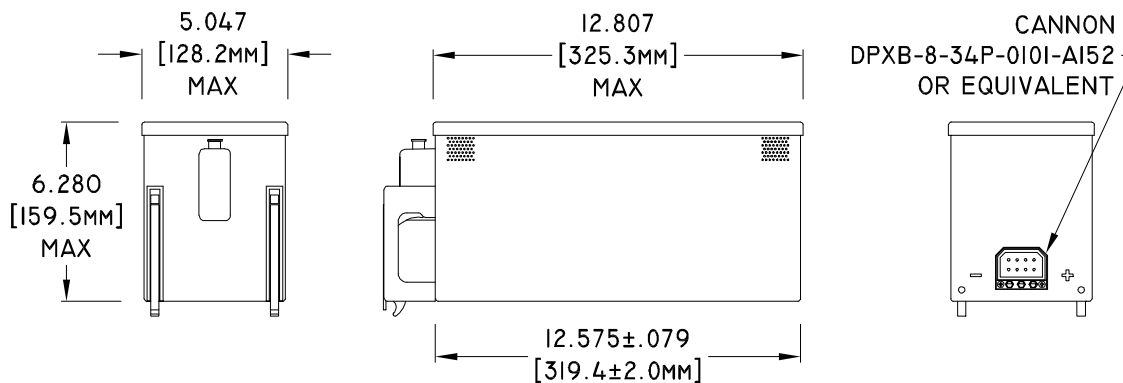

...the heart of your aircraft[®]

CONCORDE[®]

Platinum Series[®]

2009 San Bernardino Road
West Covina, CA, 91790
Phone 626-813-1234 | Fax 626-813-1235
www.concordebattery.com
customer-service@concordebattery.com
ISO 9001:2000 + AS9100B