

NOTES: UNLESS OTHERWISE SPECIFIED

1. SEE DRAWING NO. CB-00288 AND PROCEDURE P-1000 FOR ASSEMBLY AND TEST INSTRUCTION. PROCEDURES AND ASSEMBLY DRAWING ARE FOR INTERNAL USE ONLY.
2. ALL TESTING IS PERFORMED IAW BATTERY COUNCIL INTERNATIONAL STANDARDS.
3. ALL DIMENSIONS ARE IN INCHES [MM]
4. TERMINAL HARDWARE KIT PROVIDED, PART NUMBER 6923

REVISIONS			
REV	DESCRIPTION	DATE	APPROVED
A	CHANGED HANDLE DIRECTION	2/26/07	JBT
B	CHANGED COVER & HANDLE, NOM. WT. 90 lbs WAS 82 lbs	11/6/07	JBT
C	REVISED TERMINAL DAMS, TERMINAL HEIGHT & HANDLES	9/16/09	JBT

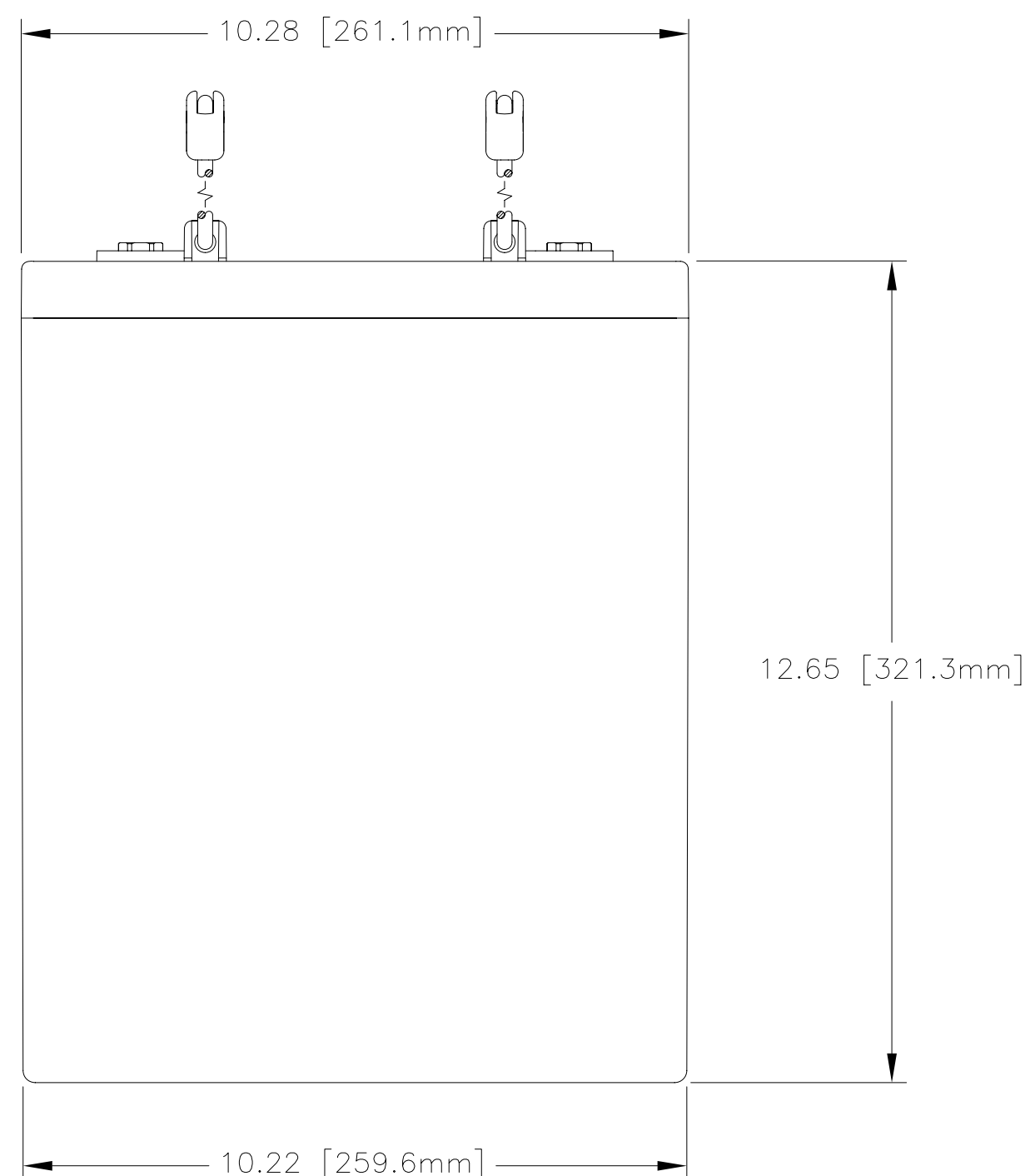
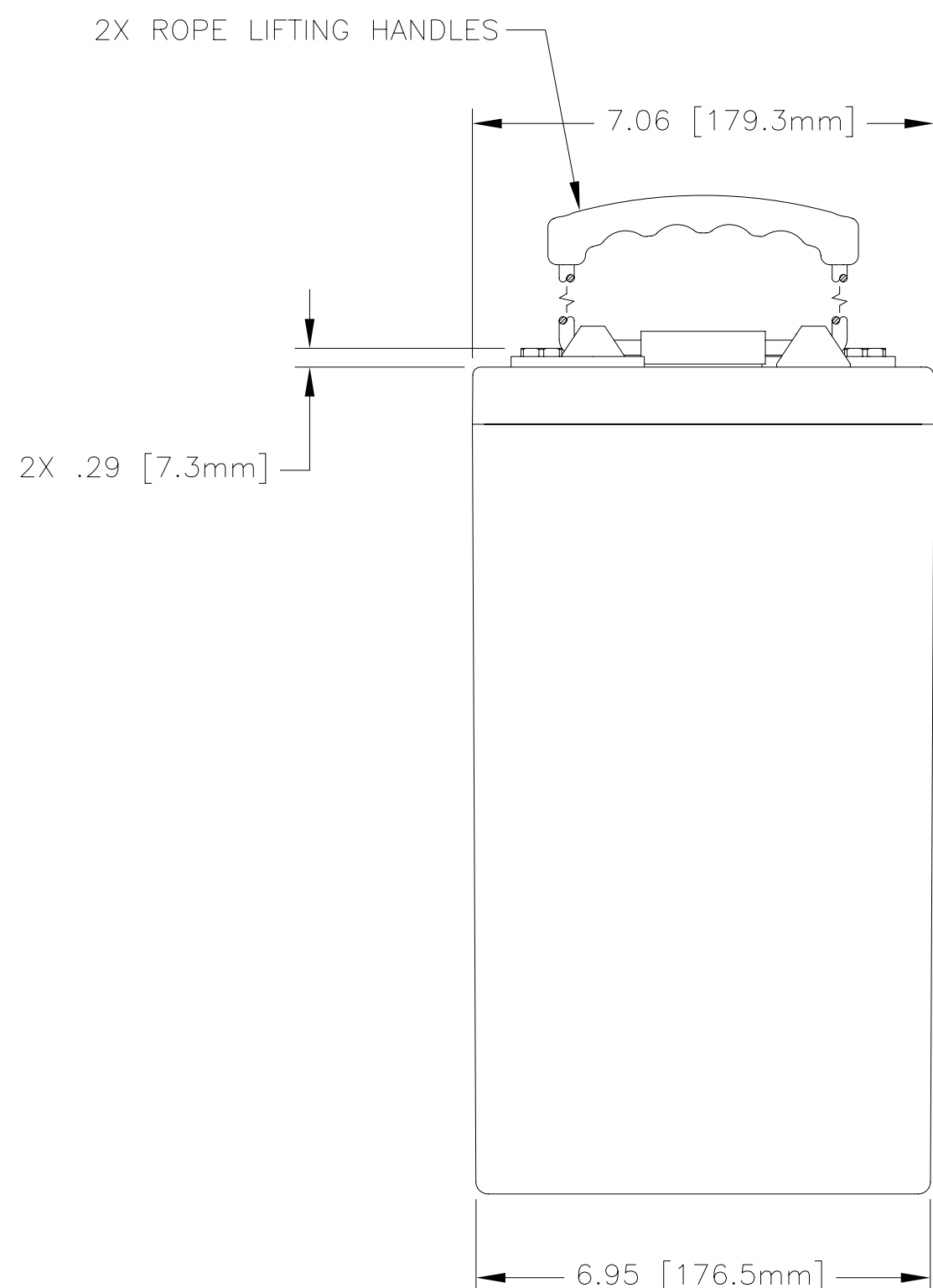
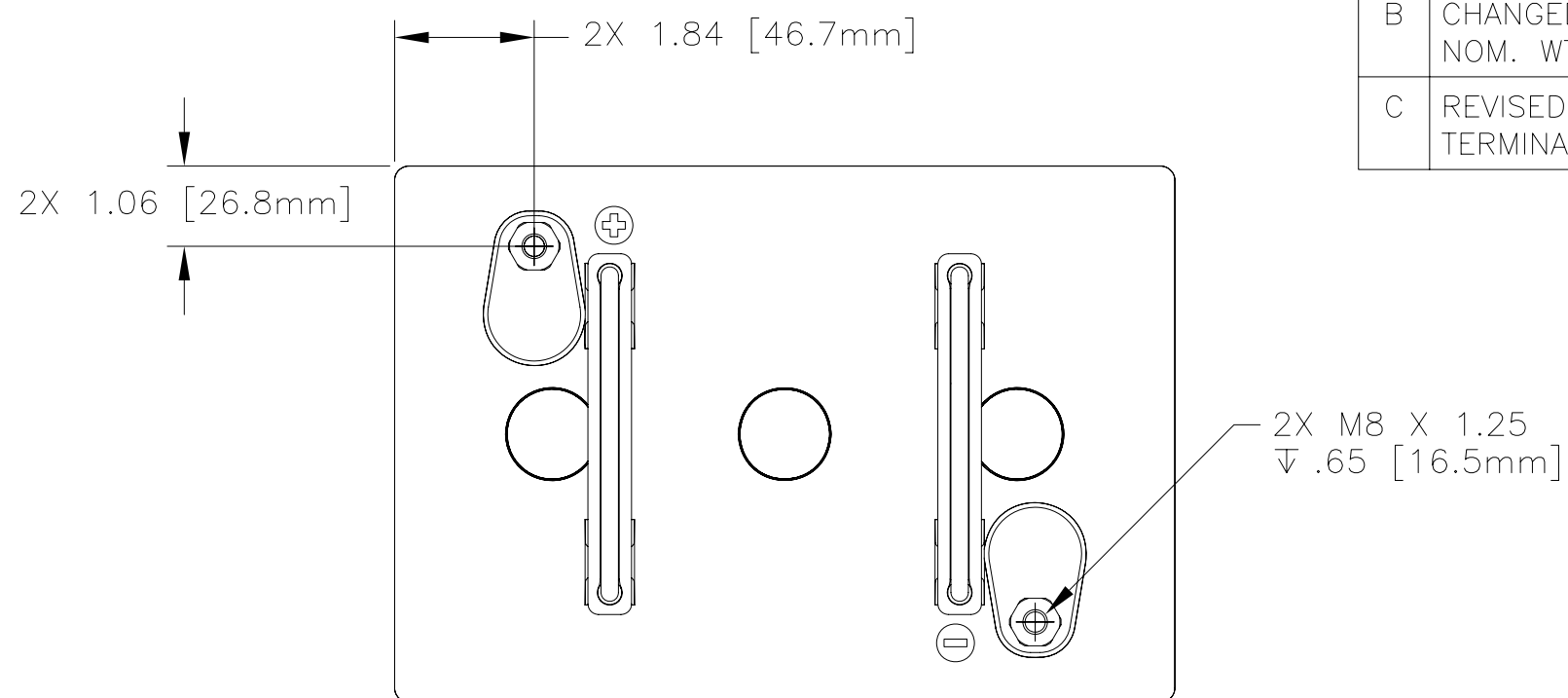

CAPACITY RATINGS

PART NUMBER	AGM-6300T
NOMINAL WEIGHT	90 LBS [40.8 KG]
AMPERE HOUR CAPACITY @ 20 HOUR 1.75 VOLTS/CELL @ 77°F (25° C)	300 AH
MINUTES OF DISCHARGE @ 25 AMPS 1.75 VOLTS/CELL @ 77°F (25° C)	692 MIN

ENVELOPE DRAWING

QTY REQD	CAGE CODE	PART OR IDENTIFYING NO.	NOMENCLATURE OR DESCRIPTION	MATERIAL SPECIFICATION	ITEM NO.
PARTS LIST					
UNLESS OTHERWISE SPECIFIED DIMENSIONS ARE IN INCHES TOLERANCES ARE:			CONCORDE BATTERY CORPORATION 2009 SAN BERNARDINO RD, W. COVINA, CA 91790		
FRACTIONS	DECIMALS	ANGLES	APPROVALS	DATE	TITLE
± 1/32	.XX ± .12	± 1°	DRAWN D. AYALA	12/15/06	BATTERY, 6 VOLT, AGM-6300T
	.XXX ± .060		CHECKED AMIII	1/9/07	SIZE C
TREATMENT	NONE		APPROVED JBT	1/10/07	CAGE CODE 63017
FINISH	NONE		ISSUED JJ	9/18/09	DWG NO. AGM-6300T
SIMILAR TO N/A	ACT WT N/A	CALC WT N/A			SCALE 1=2.5
				SHEET 1 OF 1	REV C