

NOTES: UNLESS OTHERWISE SPECIFIED

1. SEE DRAWING NO. CB-00281 AND PROCEDURE P-1000 FOR ASSEMBLY AND TEST INSTRUCTION. PROCEDURES AND ASSEMBLY DRAWING ARE FOR INTERNAL USE ONLY.
2. ALL TESTING IS PERFORMED IAW BATTERY COUNCIL INTERNATIONAL STANDARDS.
3. ALL DIMENSIONS ARE IN INCHES [MM]
4. TERMINAL HARDWARE KIT PROVIDED, PART NUMBER 6923

REVISIONS			
REV	DESCRIPTION	DATE	APPROVED
C	UPDATED RATINGS	1/30/08	JBT
D	REVISED TERMINAL DAMS, TERMINAL HEIGHT & HANDLES	9/16/09	JBT

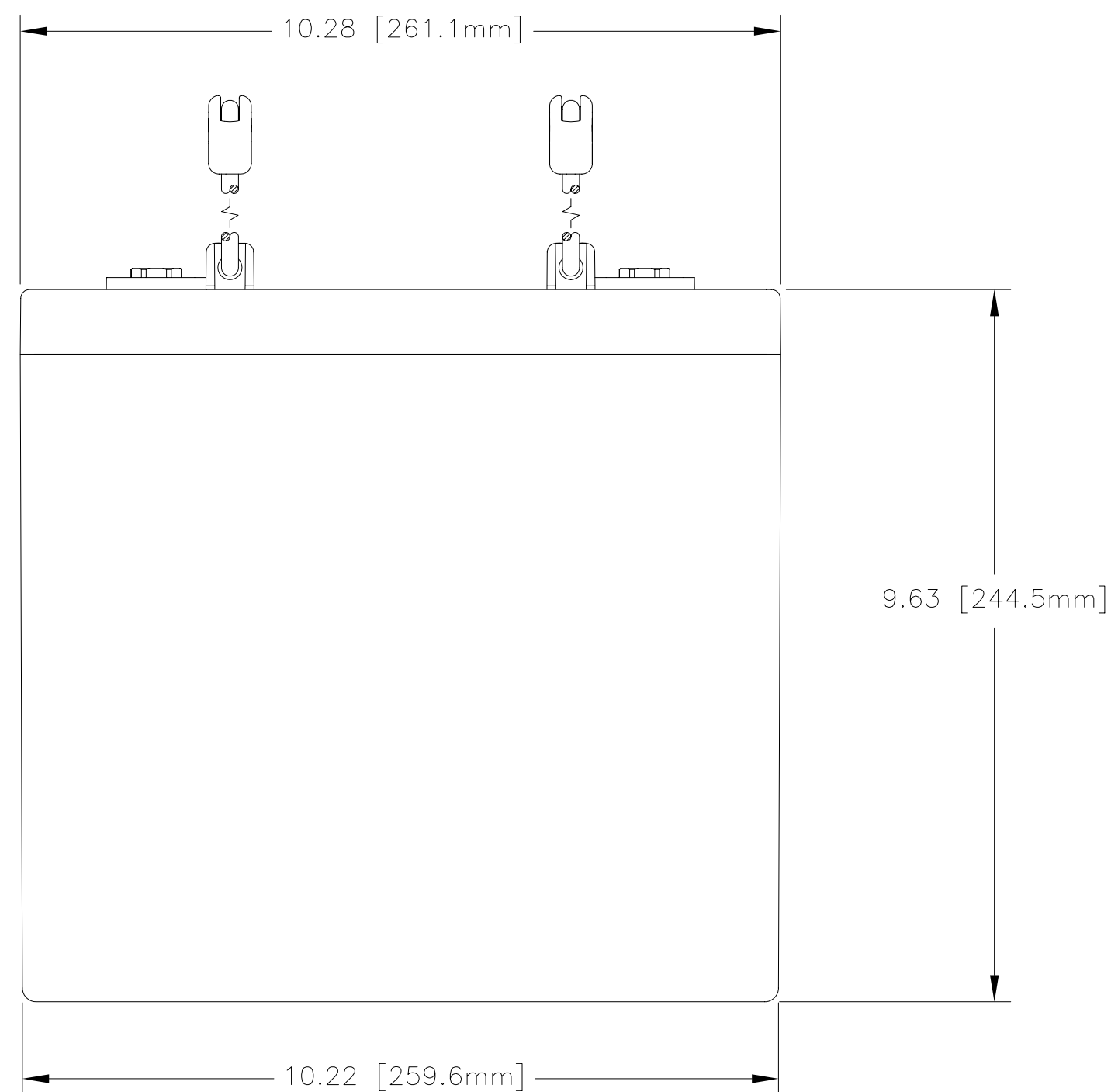
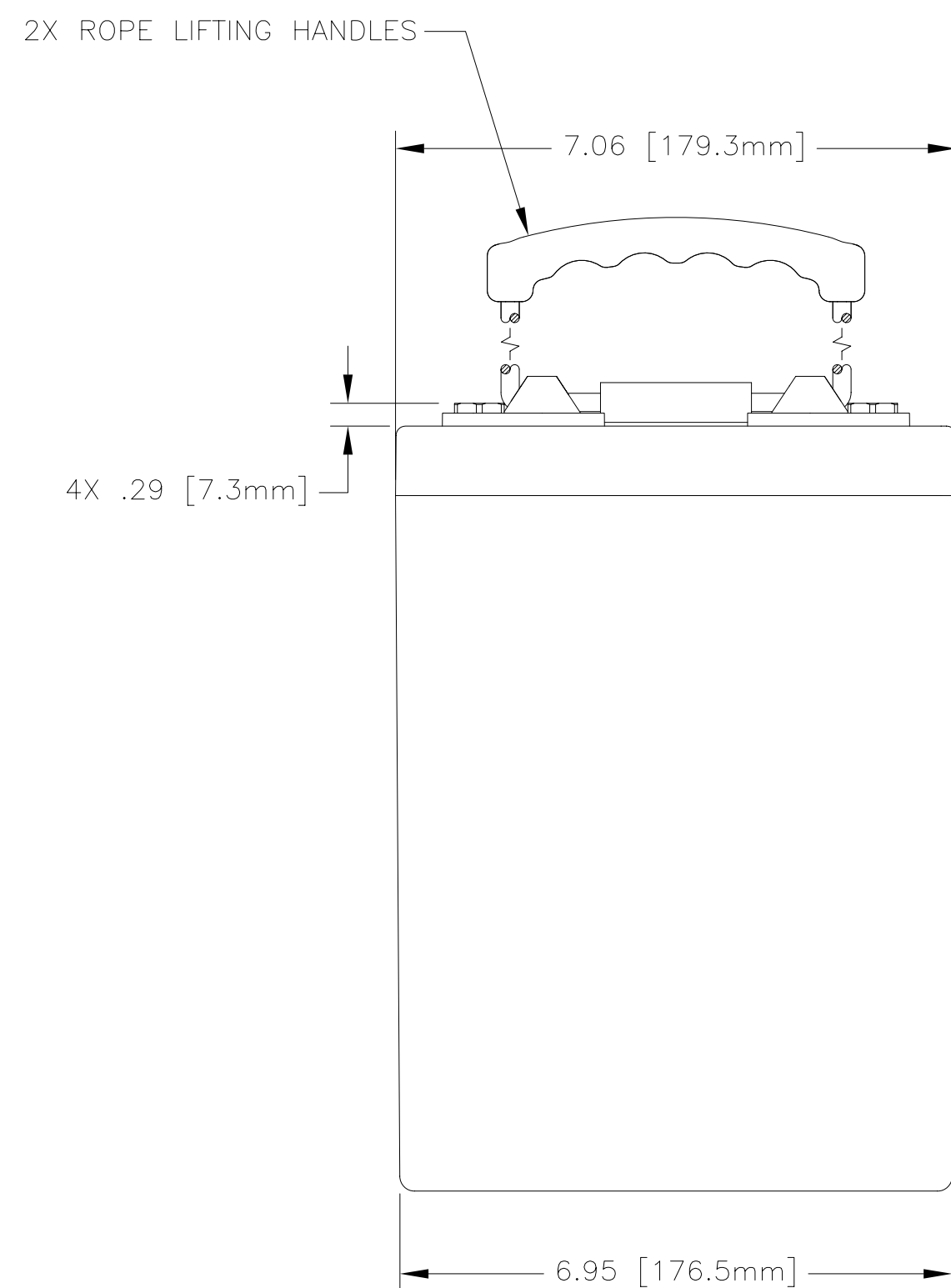
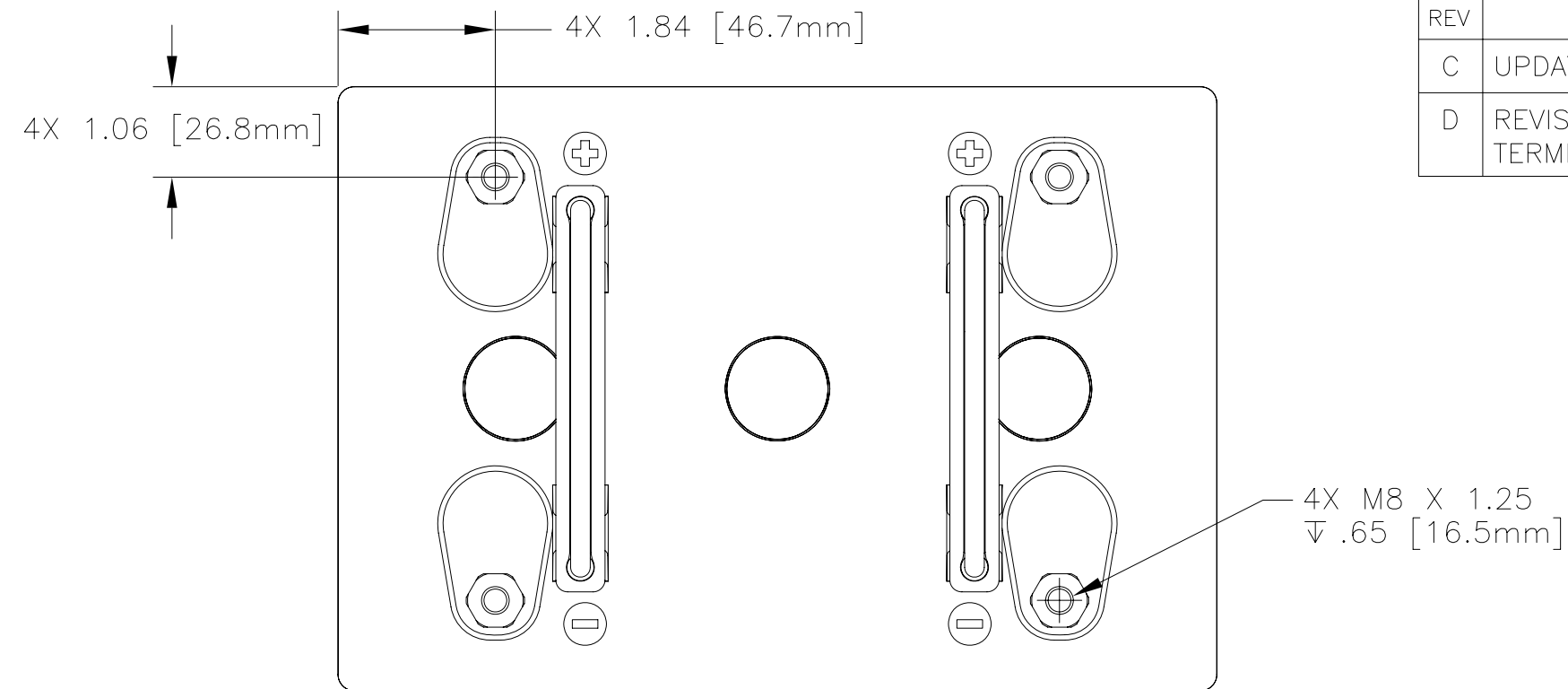

ENVELOPE DRAWING

CAPACITY RATINGS	
PART NUMBER	AGM-2660T
NOMINAL WEIGHT	69 LBS [31.3 KG]
AMPERE HOUR CAPACITY @ 20 HOUR 1.75 VOLTS/CELL @ 77°F (25° C)	660 AH
MINUTES OF DISCHARGE @ 25 AMPS 1.75 VOLTS/CELL @ 77°F (25° C)	1476 MIN

QTY REQD	CAGE CODE	PART OR IDENTIFYING NO.	NOMENCLATURE OR DESCRIPTION	MATERIAL SPECIFICATION	ITEM NO.
PARTS LIST					
UNLESS OTHERWISE SPECIFIED DIMENSIONS ARE IN INCHES TOLERANCES ARE:			CONCORDE BATTERY CORPORATION 2009 SAN BERNARDINO RD, W. COVINA, CA 91790		
FRACTIONS	DECIMALS	ANGLES	APPROVALS	DATE	TITLE
± 1/32	.XX ± .12	± 1°	DRAWN D. AYALA	12/15/06	BATTERY, 2 VOLT, AGM-2660T
	.XXX ± .060		CHECKED AMIII	1/9/07	
TREATMENT	NONE		APPROVED JBT	1/10/07	
FINISH	NONE		ISSUED JJ	9/18/09	
SIMILAR TO N/A	ACT WT N/A	CALC WT N/A	SCALE 1/2	CAGE CODE 63017	DWG NO. AGM-2660T
			SHEET 1 OF 1	REV D	