

NOTES: UNLESS OTHERWISE SPECIFIED

1. SEE DRAWING NO. CB-00278 AND PROCEDURE P-1000 FOR ASSEMBLY AND TEST INSTRUCTION. PROCEDURES AND ASSEMBLY DRAWINGS ARE FOR INTERNAL USE ONLY.
2. ALL TESTING ARE IAW BATTERY COUNCIL INTERNATIONAL STANDARDS.
3. ALL DIMENSIONS ARE IN INCHES [MM].

REVISIONS			
REV	DESCRIPTION	DATE	APPROVED
A	REVISED CAPACITY TABLE	3/15/00	JBT
B	METRICIZED INSERT	12/23/00	JBT
C	REMOVED SIDE HOLD-DOWNS	7/23/01	JBT

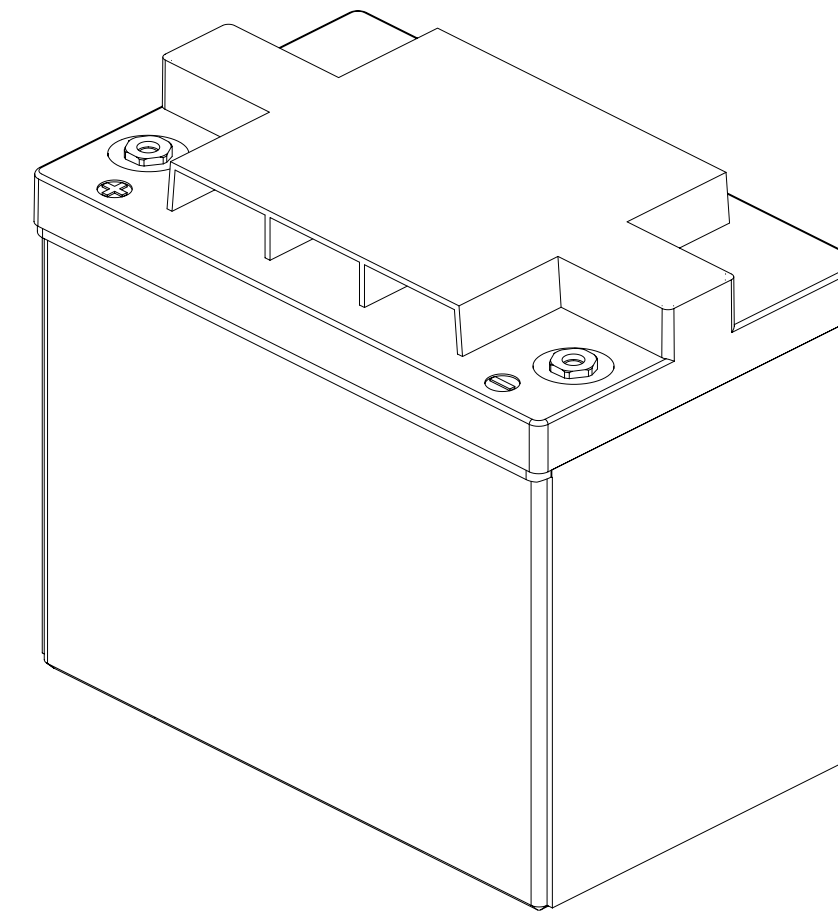
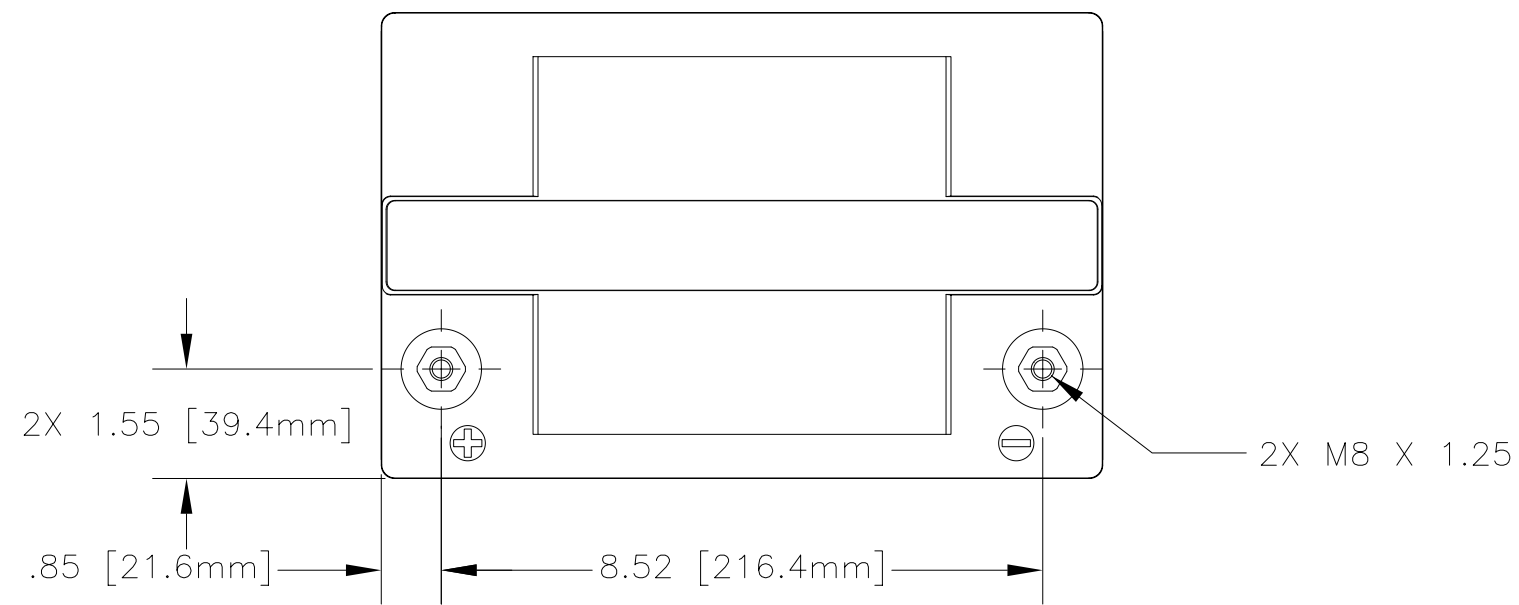

REFERENCE VIEW

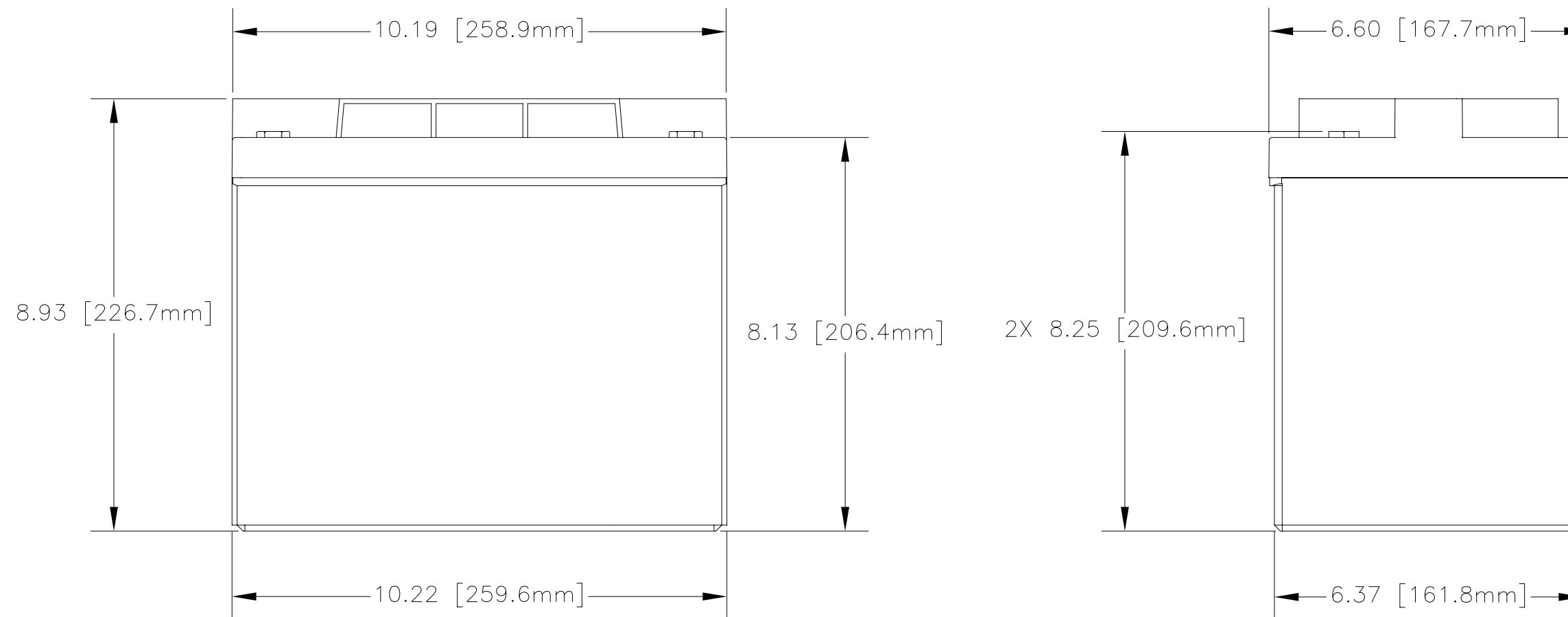

ENVELOPE DRAWING

CAPACITY RATINGS		
PART NUMBER	AGM-1265T	AGM-1280T
NOMINAL WEIGHT	50 LBS [22.7 KG]	56 LBS [25.4 KG]
AMPERE HOUR CAPACITY @ 20 HOUR 1.75 VOLTS/CELL @ 77°F (25°C)	65 AH	80 AH
MINUTES OF DISCHARGE @ 25 AMPS 1.75 VOLTS/CELL @ 77°F (25°C)	121 MIN	149 MIN

QTY REQD	CAGE CODE	PART OR IDENTIFYING NO.	NOMENCLATURE OR DESCRIPTION	MATERIAL SPECIFICATION	ITEM NO.
PARTS LIST					
UNLESS OTHERWISE SPECIFIED DIMENSIONS ARE IN INCHES TOLERANCES ARE: FRACTIONS DECIMALS ANGLES .XX ± .06 .XXX ± .030			CONCORDE BATTERY CORPORATION 2009 SAN BERNARDINO RD, W. COVINA, CA 91790		
TREATMENT NONE		APPROVALS DATE		TITLE	
FINISH NONE		DRAWN ELH 3/01/00		BATTERY, 12 VOLT, AGM-1280T SERIES	
SIMILAR TO NA		CHECKED S. VALDEZ 3/01/00		SIZE CAGE CODE DWG NO.	
ACT WT NA CALC WT NA		APPROVED JBT 3/04/00		C 63017 AGM-1280T	
		ISSUED AT 8/6/01		REV C	
SCALE NONE				SHEET 1 OF 1	

ENGINEERING COPY 06AUG01