

NOTES: UNLESS OTHERWISE SPECIFIED

1. SEE DRAWING NO. CB-00282 AND PROCEDURE P-1000 FOR ASSEMBLY AND TEST INSTRUCTION. PROCEDURES AND ASSEMBLY DRAWINGS ARE FOR INTERNAL USE ONLY.
2. ALL TESTING ARE IAW BATTERY COUNCIL INTERNATIONAL STANDARDS.
3. ALL DIMENSIONS ARE IN INCHES [MM].

REVISIONS			
REV	DESCRIPTION	DATE	APPROVED
A	METRICIZED INSERT	12/23/00	JBT
B	REVISED HEIGHT DIMS	8/2/13	JBT

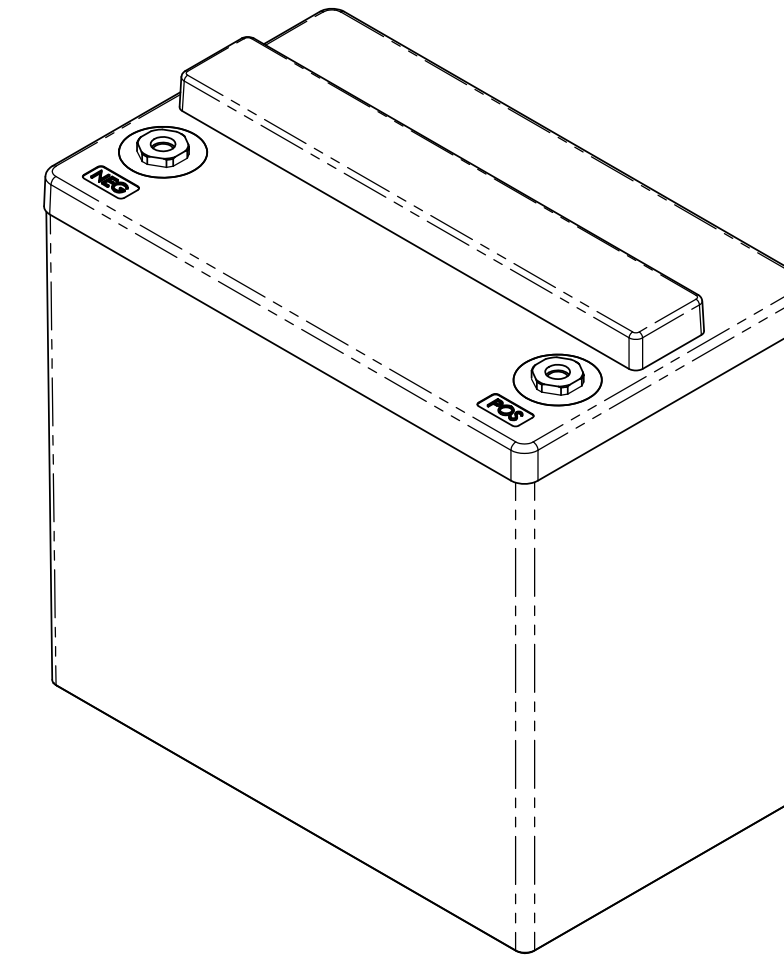
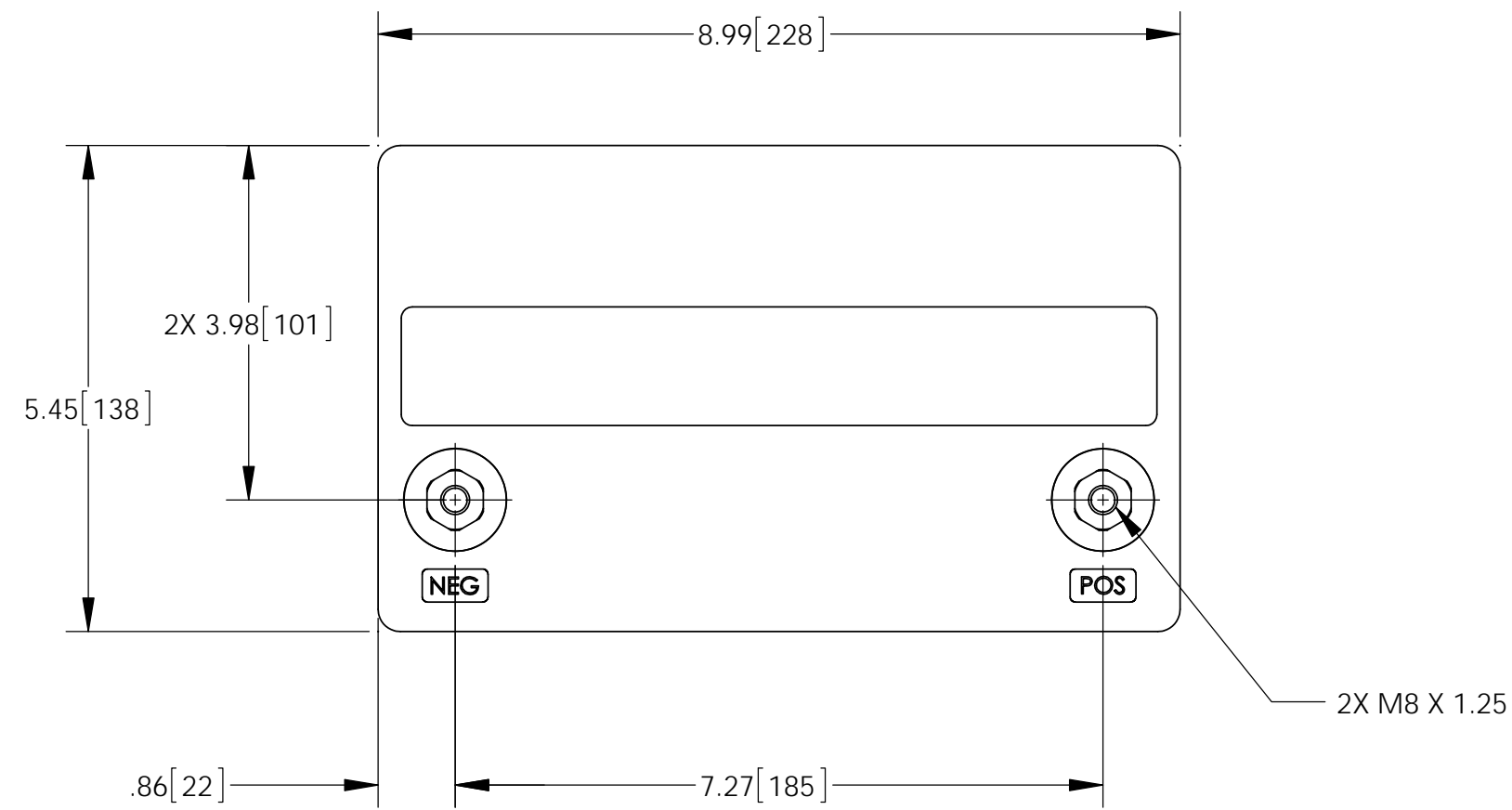

REFERENCE VIEW

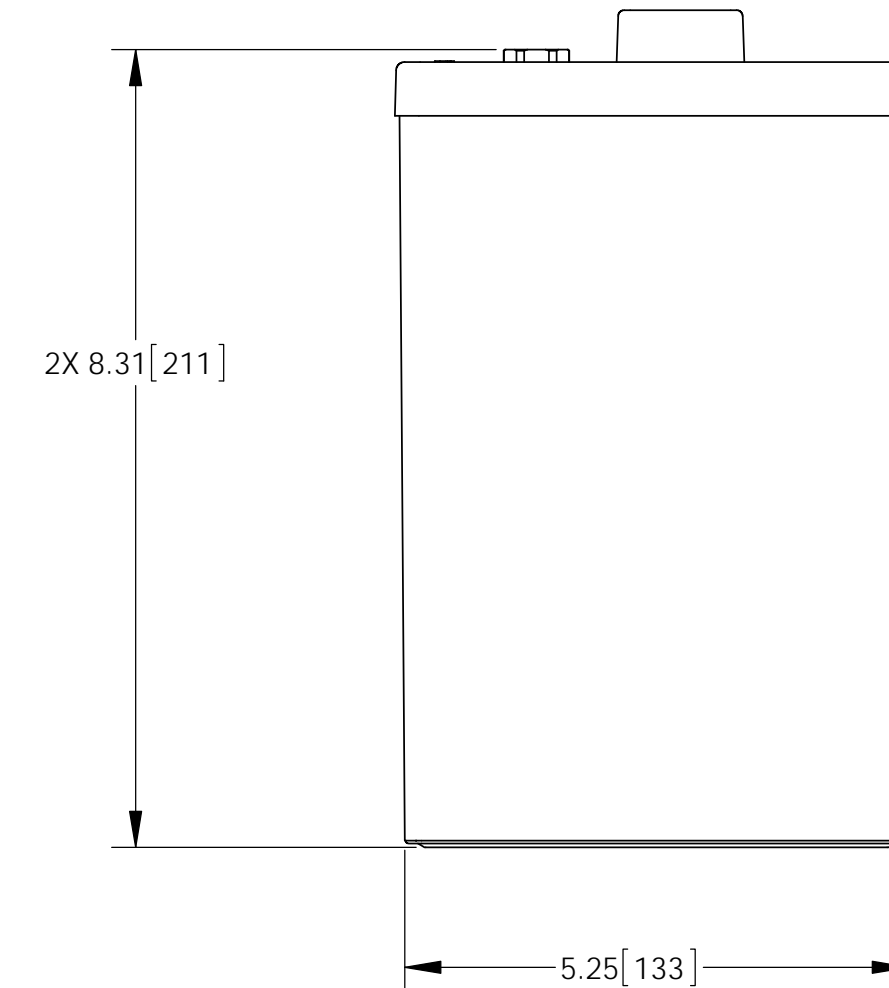
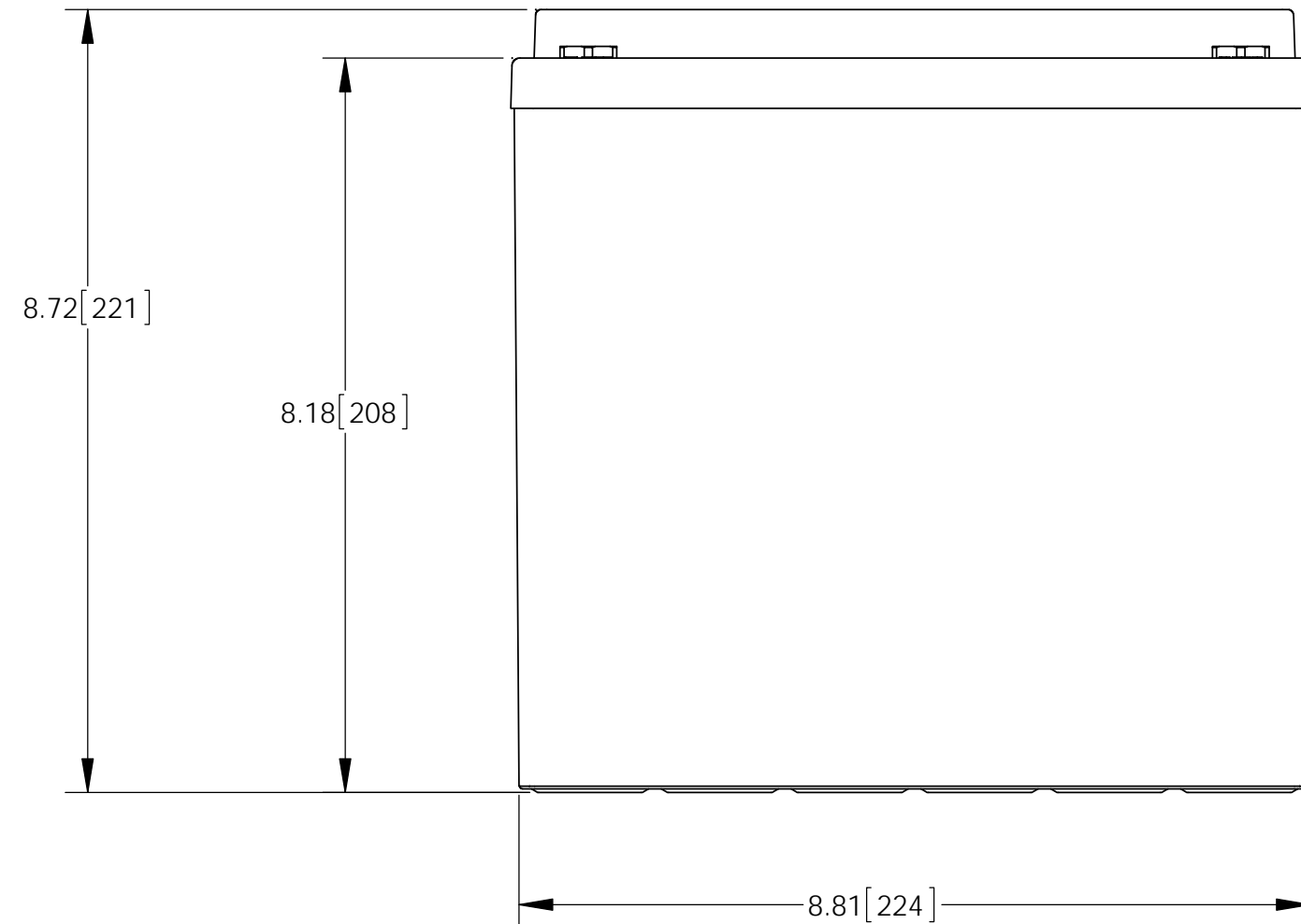

ENVELOPE DRAWING

CAPACITY RATINGS		
PART NUMBER	AGM-1248T	AGM-1255T
NOMINAL WEIGHT	35 LBS [15.9 KG]	39 LBS [17.7 KG]
AMPERE HOUR CAPACITY @20 HOUR 1.75 VOLTS/CELL @77° F (25° C)	48 AH	55 AH
MINUTES OF DISCHARGE @25 AMPS 1.75 VOLTS/CELL @77° F (25° C)	84 MIN	96 MIN

UNLESS OTHERWISE SPECIFIED DIMENSIONS ARE IN INCHES TOLERANCES ARE:			CONTRACT NO.		CONCORDE BATTERY CORPORATION 2009 SAN BERNARDINO RD, W. COVINA, CA 91790			
FRACTIONS	DECIMALS	ANGLES	APPROVALS		DATE		TITLE	
±1/32	.XX ± .06 XXX ± .030	±1°	DRAWN ELH		3/16/00		BATTERY, 12 VOLT, AGM-1255T SERIES	
TREATMENT	NONE		CHECKED S. VALDEZ		3/16/00		SIZE	REV
FINISH	NONE		APPROVED DG		3/23/00		CAGE CODE	
SIMILAR TO	NA	CALC W/	ISSUED	BT	8/5/13	SCALE	1:2	
	NA							
							DWG NO.	AGM-1255T
							REV	B
							SHEET	1 OF 1