

NOTES: UNLESS OTHERWISE SPECIFIED

1. SEE DRAWING NO. CB-00282 AND PROCEDURE P-1000 FOR ASSEMBLY AND TEST INSTRUCTION. PROCEDURES AND ASSEMBLY DRAWINGS ARE FOR INTERNAL USE ONLY.
2. ALL TESTING ARE IAW BATTERY COUNCIL INTERNATIONAL STANDARDS.
3. ALL DIMENSIONS ARE IN INCHES [MM].

REVISIONS			
REV	DESCRIPTION	DATE	APPROVED
A	METRICIZED INSERT	12/23/00	JBT

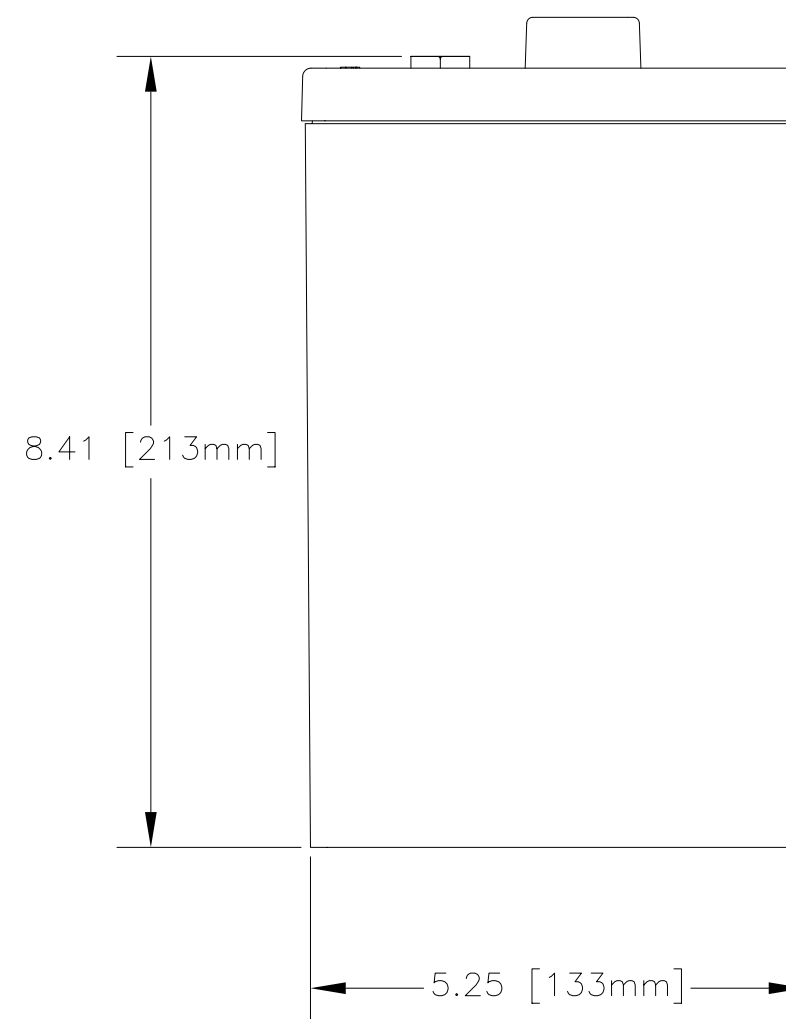
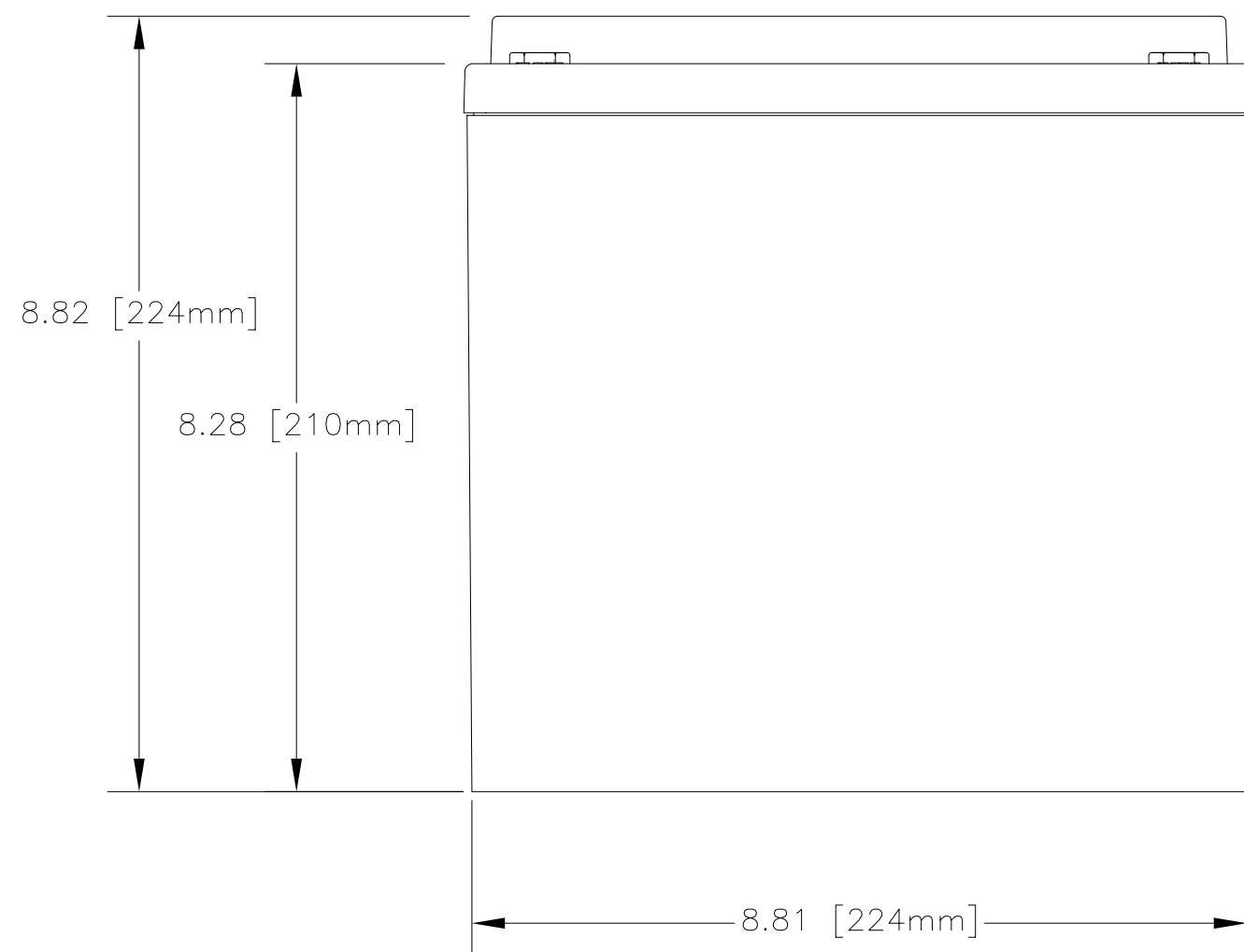
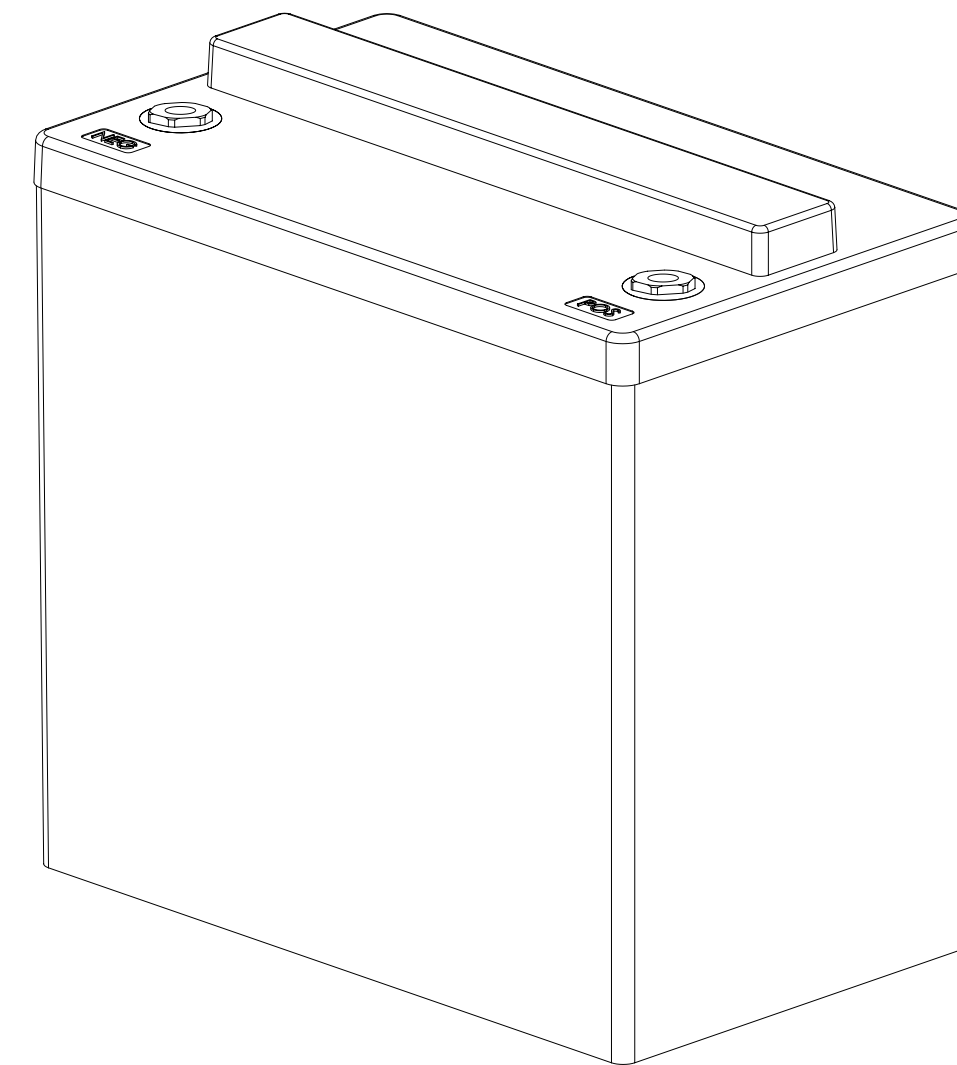
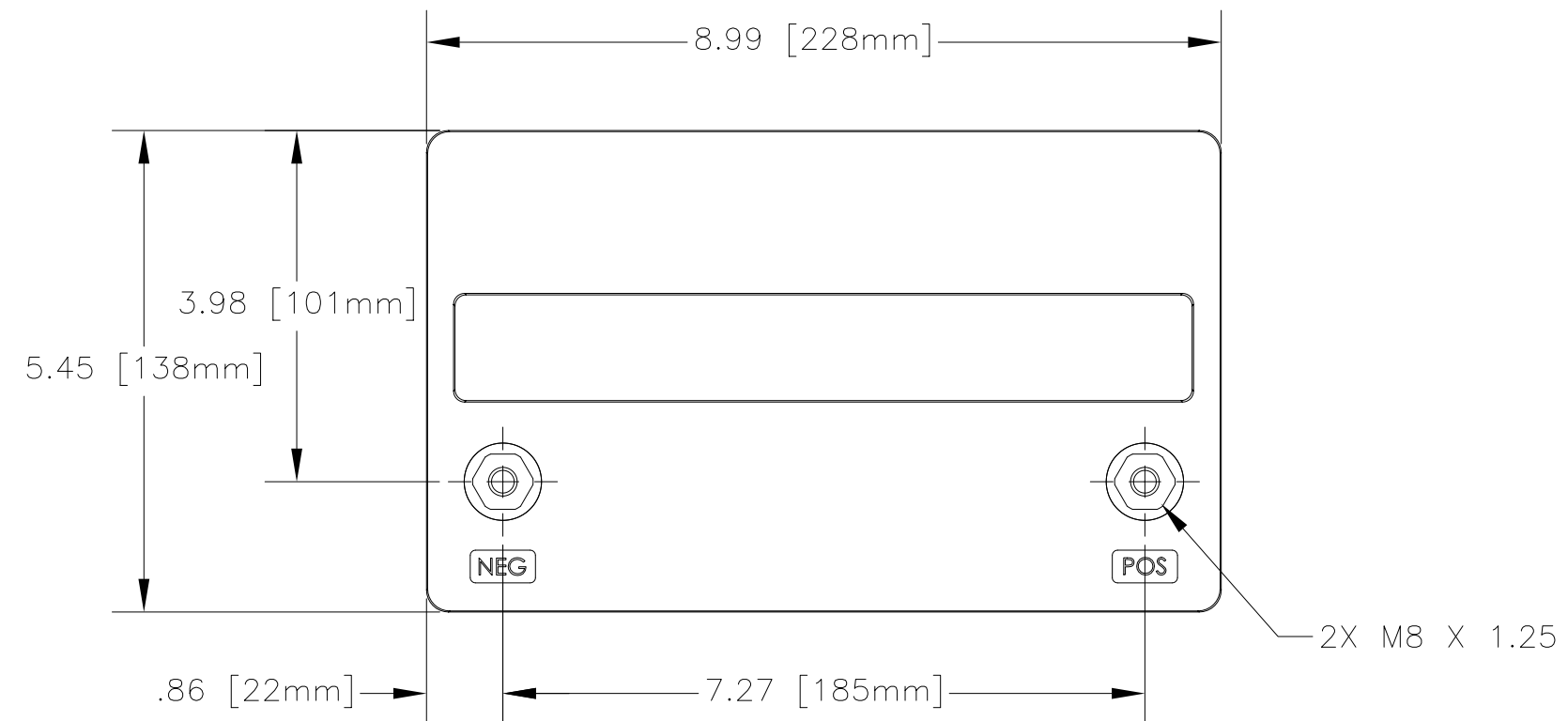

CAPACITY RATINGS		
PART NUMBER	AGM-1248T	AGM-1255T
NOMINAL WEIGHT	35 LBS[15.9 KG]	39 LBS[17.7 KG]
AMPERE HOUR CAPACITY @ 20 HOUR 1.75 VOLTS/CELL @ 77°F (25° C)	48 AH	55 AH
MINUTES OF DISCHARGE @ 25 AMPS 1.75 VOLTS/CELL @ 77°F (25° C)	84 MIN	96 MIN

QTY REQD	CAGE CODE	PART OR IDENTIFYING NO.	NOMENCLATURE OR DESCRIPTION	MATERIAL SPECIFICATION	ITEM NO.
PARTS LIST					
UNLESS OTHERWISE SPECIFIED DIMENSIONS ARE IN INCHES TOLERANCES ARE: FRACTIONS DECIMALS ANGLES .XX ± .06 .XXX ± .060			CONCORDE BATTERY CORPORATION 2009 SAN BERNARDINO RD, W. COVINA, CA 91790		
TREATMENT NONE		CONTRACT NO.	TITLE BATTERY, 12 VOLT, AGM-1255T SERIES		
FINISH NONE		APPROVALS	DATE	SIZE	CAGE CODE
SIMILAR TO N/A		DRAWN ELH	3/16/00	C	63017
ACT WT N/A		CHECKED S. VALDEZ	3/16/00	DWG NO.	AGM-1255T
CALC WT N/A		APPROVED DG	3/23/00	REV	A
		ISSUED AT	1/11/01	SCALE	NONE
				SHEET	1 OF 1

ENGINEING COPY 11-JAN01