

NOTES: UNLESS OTHERWISE SPECIFIED

1. SEE DRAWING NO. CB-00293 AND PROCEDURE P-1000 FOR ASSEMBLY AND TEST INSTRUCTION. PROCEDURES AND ASSEMBLY DRAWINGS ARE FOR INTERNAL USE ONLY.
2. ALL TESTING ARE IAW BATTERY COUNCIL INTERNATIONAL STANDARDS.
3. ALL DIMENSIONS ARE IN INCHES [MM].

REVISIONS			
REV	DESCRIPTION	DATE	APPROVED
A	REVISED TERMINAL WAS: M8...	12/23/00	JBT

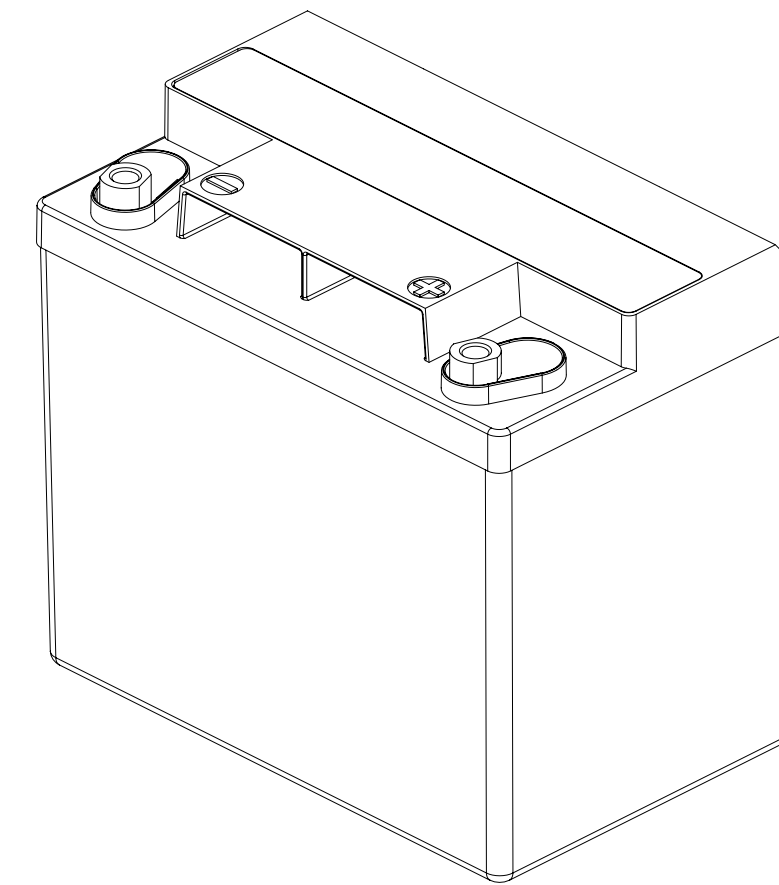
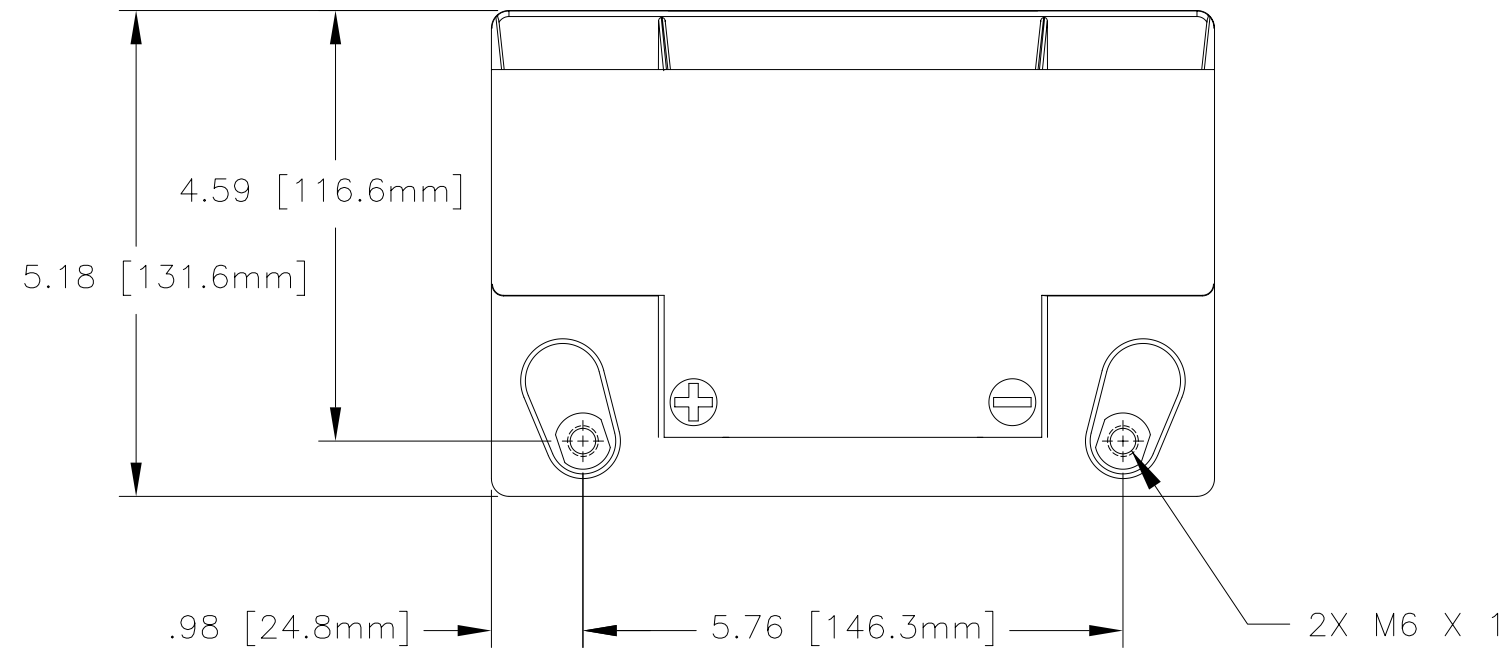

REFERANCE VIEW

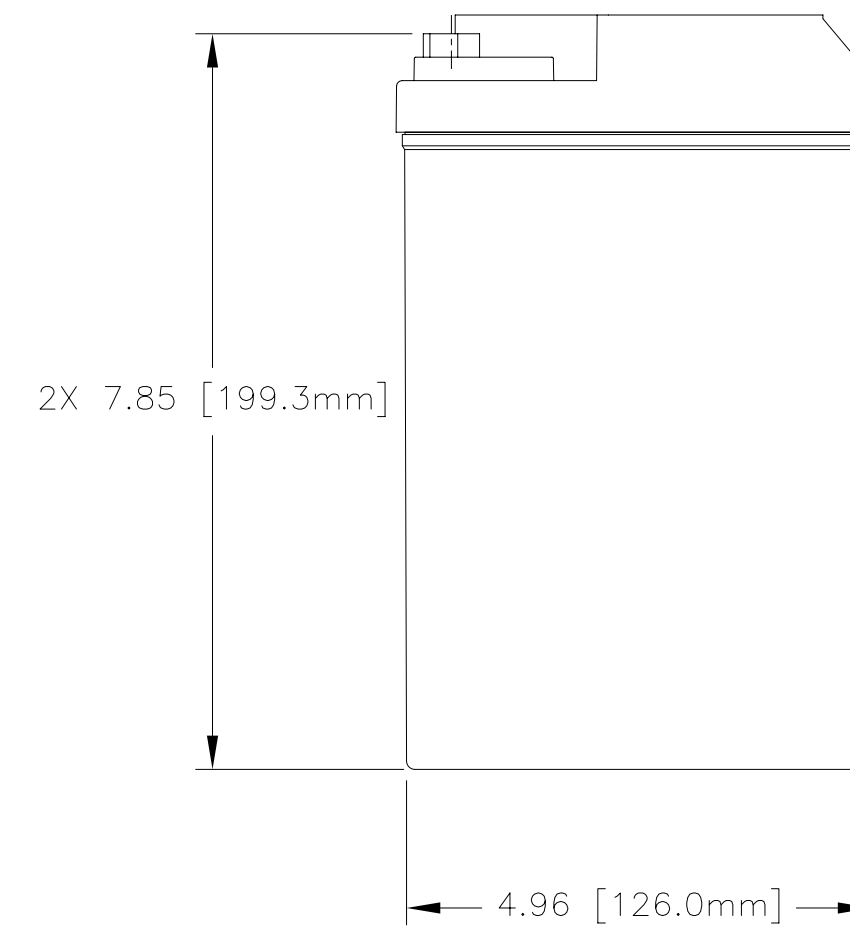
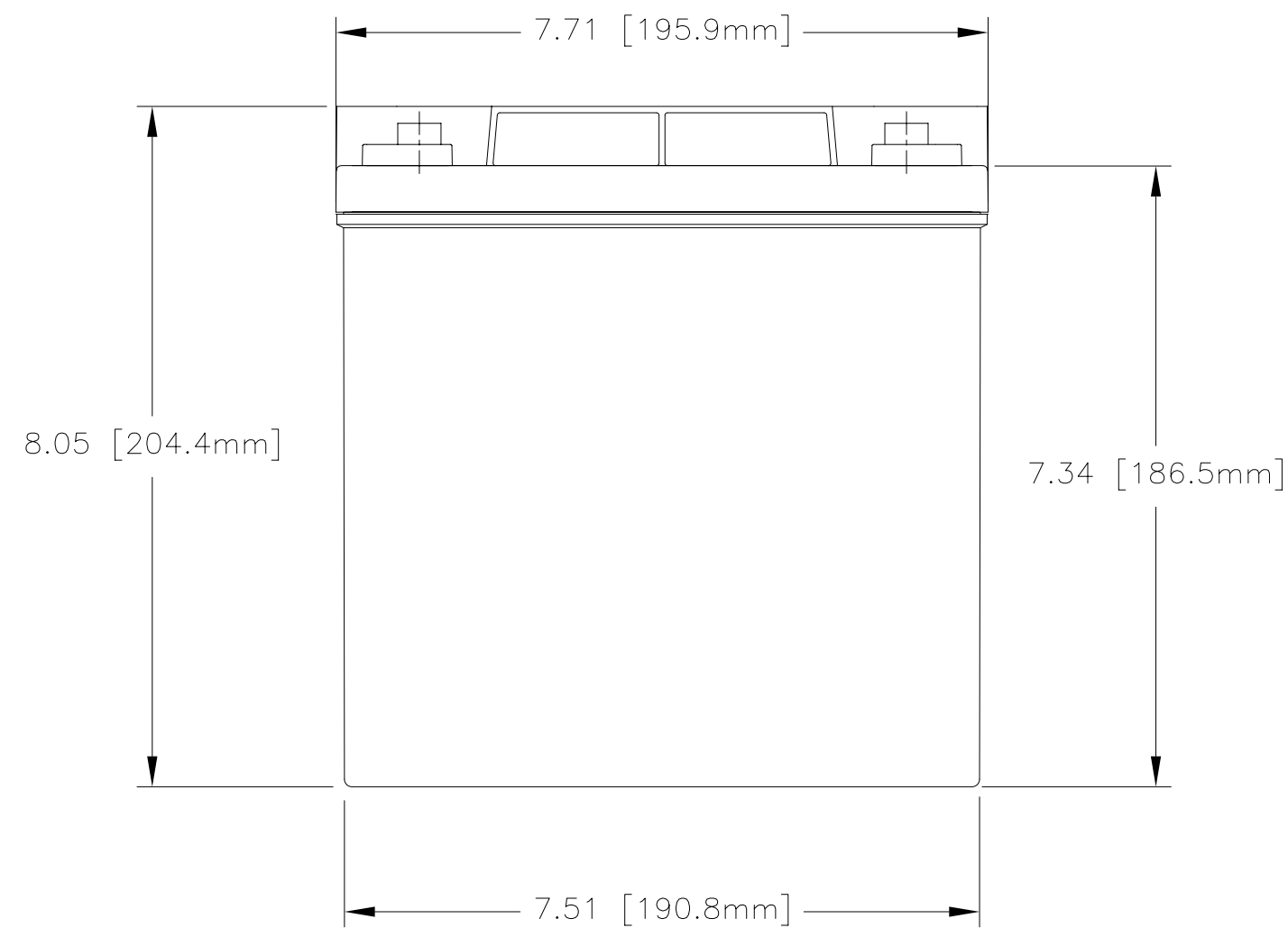

ENVELOPE DRAWING

CAPACITY RATINGS	
PART NUMBER	AGM-1240T
NOMINAL WEIGHT	29 LBS[13.2 KG]
AMPERE HOUR CAPACITY @ 20 HOUR 1.75 VOLTS/CELL @ 77°F (25° C)	40 AH
MINUTES OF DISCHARGE @ 25 AMPS 1.75 VOLTS/CELL @ 77°F (25° C)	61 MIN

QTY REQD	CAGE CODE	PART OR IDENTIFYING NO.	NOMENCLATURE OR DESCRIPTION	MATERIAL SPECIFICATION	ITEM NO.
PARTS LIST					
UNLESS OTHERWISE SPECIFIED DIMENSIONS ARE IN INCHES TOLERANCES ARE: FRACTIONS DECIMALS ANGLES .XX ± .06 .XXX ± .060			CONCORDE BATTERY CORPORATION 2009 SAN BERNARDINO RD, W. COVINA, CA 91790		ITEM NO.
APPROVALS		DATE		TITLE	
DRAWN	ELH	3/21/00		BATTERY, 12 VOLT AGM-1240T	
TREATMENT	NONE	CHECKED	S. VALDEZ	3/21/00	
FINISH	NONE	APPROVED	DG	3/22/00	
SIMILAR TO	N/A	ACT WT	N/A	ISSUED	AT
SCALE NONE		01/11/01		DWG NO. AGM-1240T	
				REV A	
				SHEET 1 OF 1	

ENGINEERING COPY 11JAN01