

NOTES: UNLESS OTHERWISE SPECIFIED

1. SEE DRAWING NO. CB-00295 AND PROCEDURE P-1000 FOR ASSEMBLY AND TEST INSTRUCTION. PROCEDURES AND ASSEMBLY DRAWINGS ARE FOR INTERNAL USE ONLY.
2. ALL TESTING IS PERFORMED IAW BATTERY COUNCIL INTERNATIONAL STANDARDS.
3. ALL DIMENSIONS ARE IN INCHES [MM].

REVISIONS			
REV	DESCRIPTION	DATE	APPROVED
A	REDESIGNED CONTAINER, COVER	4/2/02	JBT
B	1.13 WAS 1.05	2/19/04	JBT
C	UPDATED HANDLES, ADDED 2X ϕ .325 DIM	5/8/08	JBT

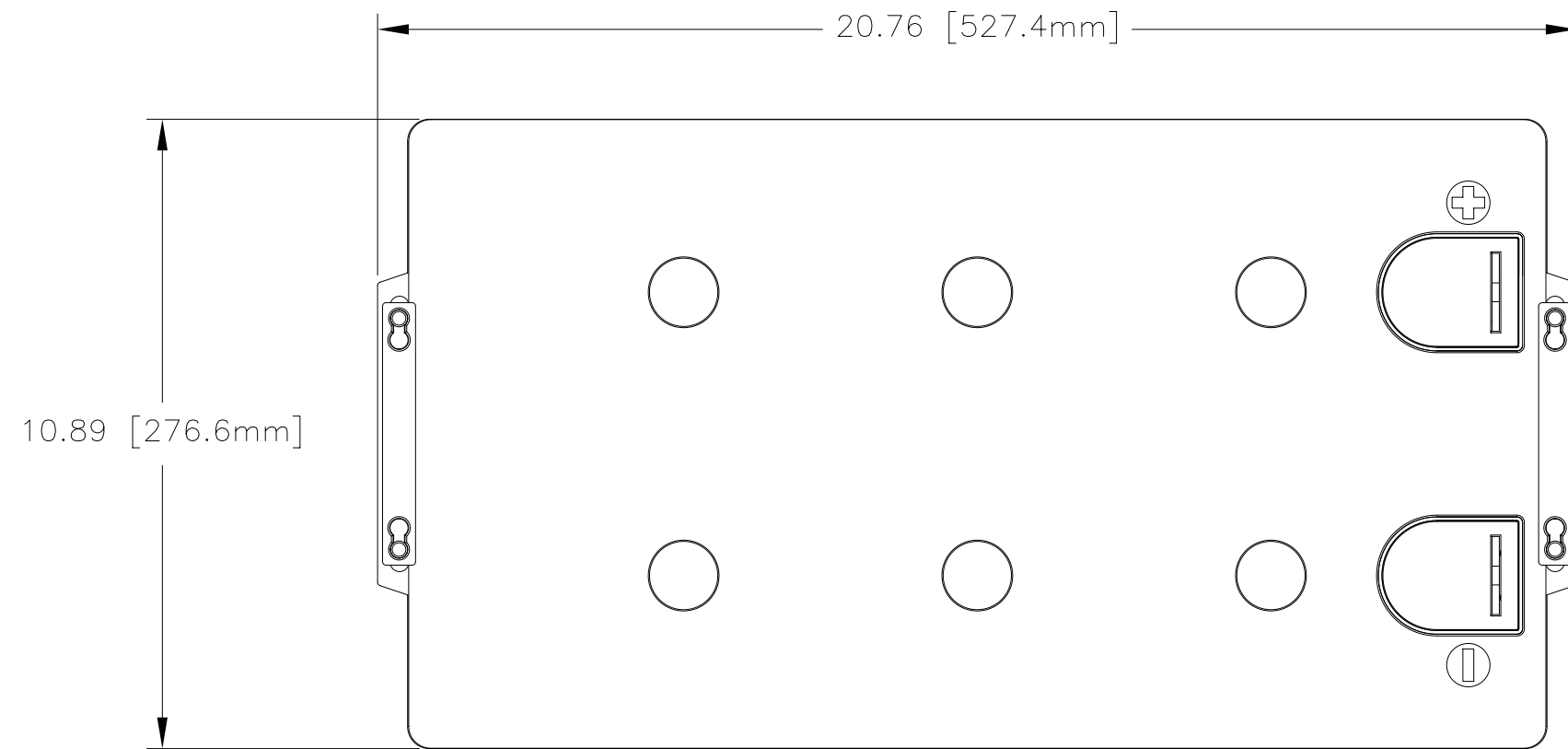

AGM-12255 TERMINAL OPTION:

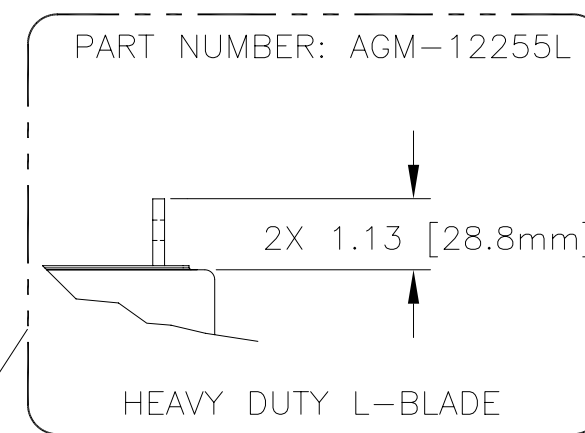

NOTE: SEE OPTION LISTED

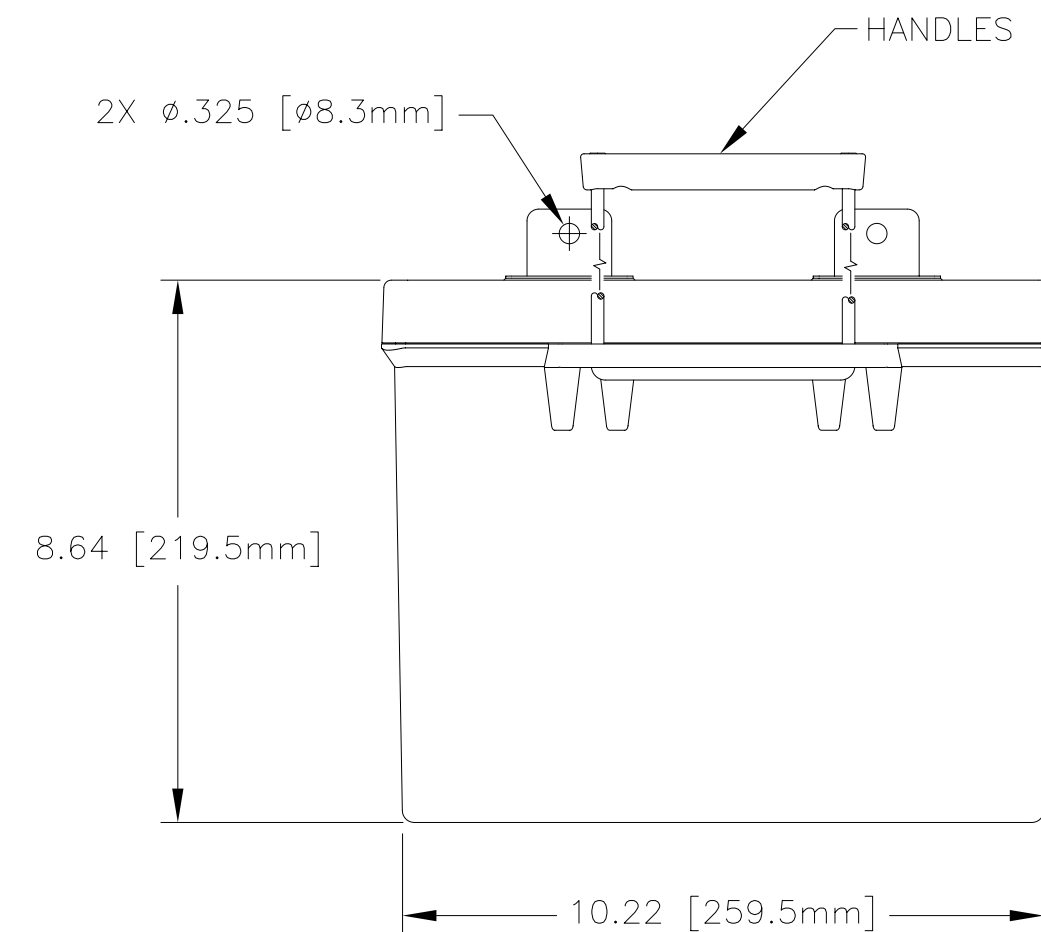

ENVELOPE DRAWING

CAPACITY RATINGS	
PART NUMBER	AGM-12255
NOMINAL WEIGHT	162 LBS[73.6 KG]
AMPERE HOUR CAPACITY @ 20 HOUR 1.75 VOLTS/CELL @ 77°F (25° C)	255 AH
MINUTES OF DISCHARGE @ 25 AMPS 1.75 VOLTS/CELL @ 77°F (25° C)	475 MIN

QTY REQD	CAGE CODE	PART OR IDENTIFYING NO.	NOMENCLATURE OR DESCRIPTION	MATERIAL SPECIFICATION	ITEM NO.
PARTS LIST					
UNLESS OTHERWISE SPECIFIED DIMENSIONS ARE IN INCHES TOLERANCES ARE: FRACTIONS DECIMALS ANGLES $\pm 1/32$.XX $\pm .06$ $\pm 1^\circ$.XXX $\pm .030$			CONCORDE BATTERY CORPORATION 2009 SAN BERNARDINO RD, W. COVINA, CA 91790		
TREATMENT		APPROVALS		TITLE	
NONE		DRAWN ELH		BATTERY, 12 VOLT, AGM-12255	
FINISH		CHECKED S. VALDEZ		DATE	DATE
NONE		APPROVED DG		3/21/00	3/21/00
SIMILAR TO NA		ACT WT NA	ISSUED NS	SCALE NONE	REV C
		CALC WT NA	5/9/08	CAGE CODE 63017	DWG NO. AGM-12255
				SHEET 1 OF 1	