

NOTES: UNLESS OTHERWISE SPECIFIED

1. SEE DRAWING NO. CB-00400 AND PROCEDURE P-1000 FOR ASSEMBLY AND TEST INSTRUCTIONS. PROCEDURES AND ASSEMBLY DRAWING ARE FOR INTERNAL USE ONLY.
2. ALL TESTING IS PERFORMED IAW BATTERY COUNCIL INTERNATIONAL STANDARDS.
3. ALL DIMENSIONS ARE IN INCHES [MILLIMETERS].

REVISIONS			
REV	DESCRIPTION	DATE	APPROVED
A	REVISED WEIGHT, 90 LBS [40.8 KG] WAS 96 LBS [43.5 KG]	12/4/12	JBT
B	REDESIGNED COVER	12/20/17	PH

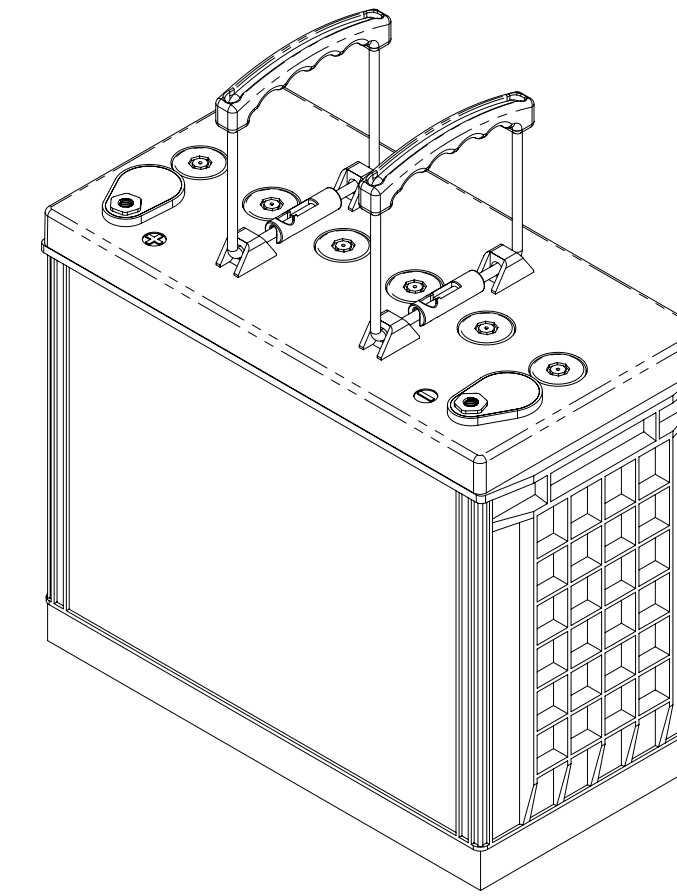
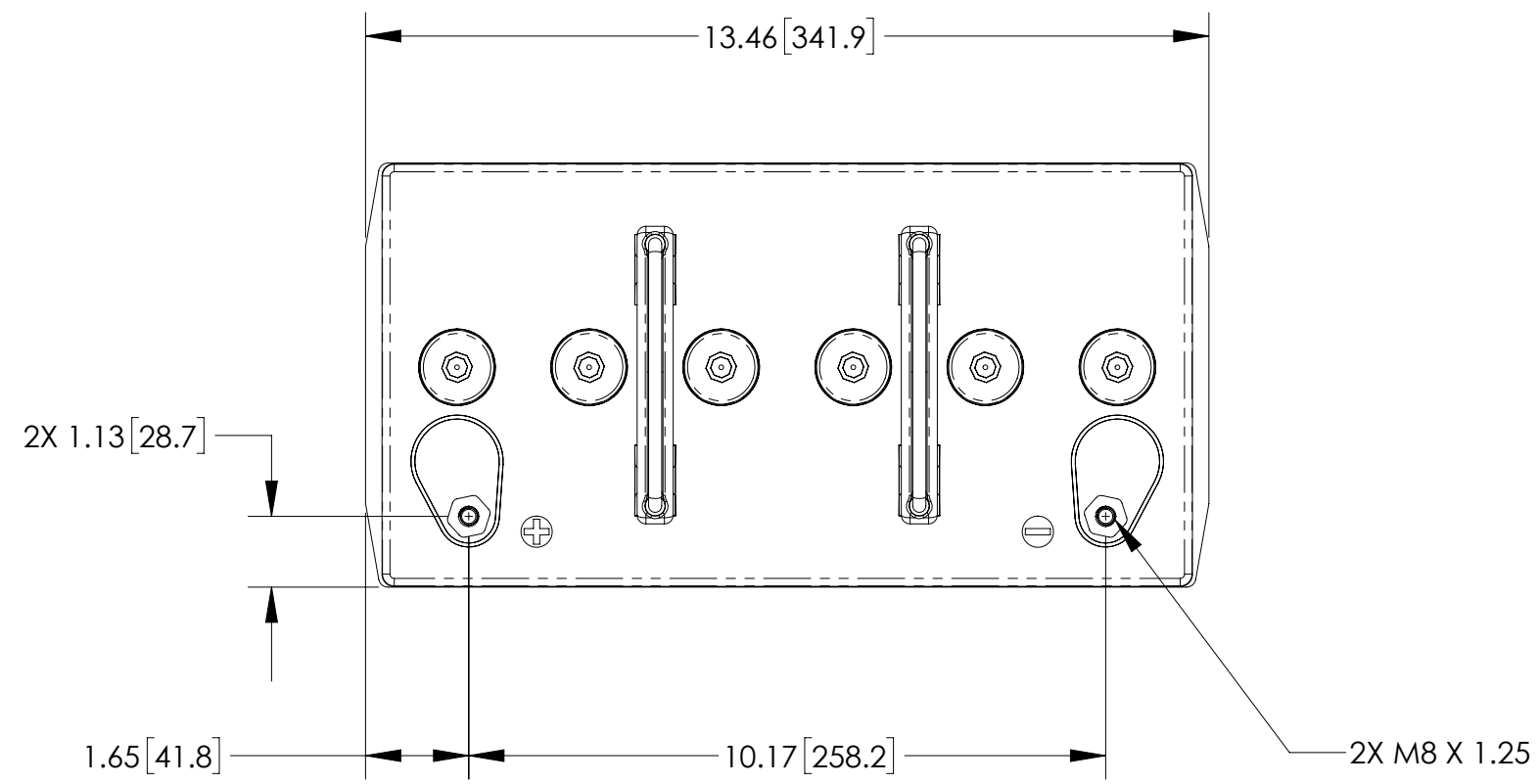

ISOMETRIC VIEW

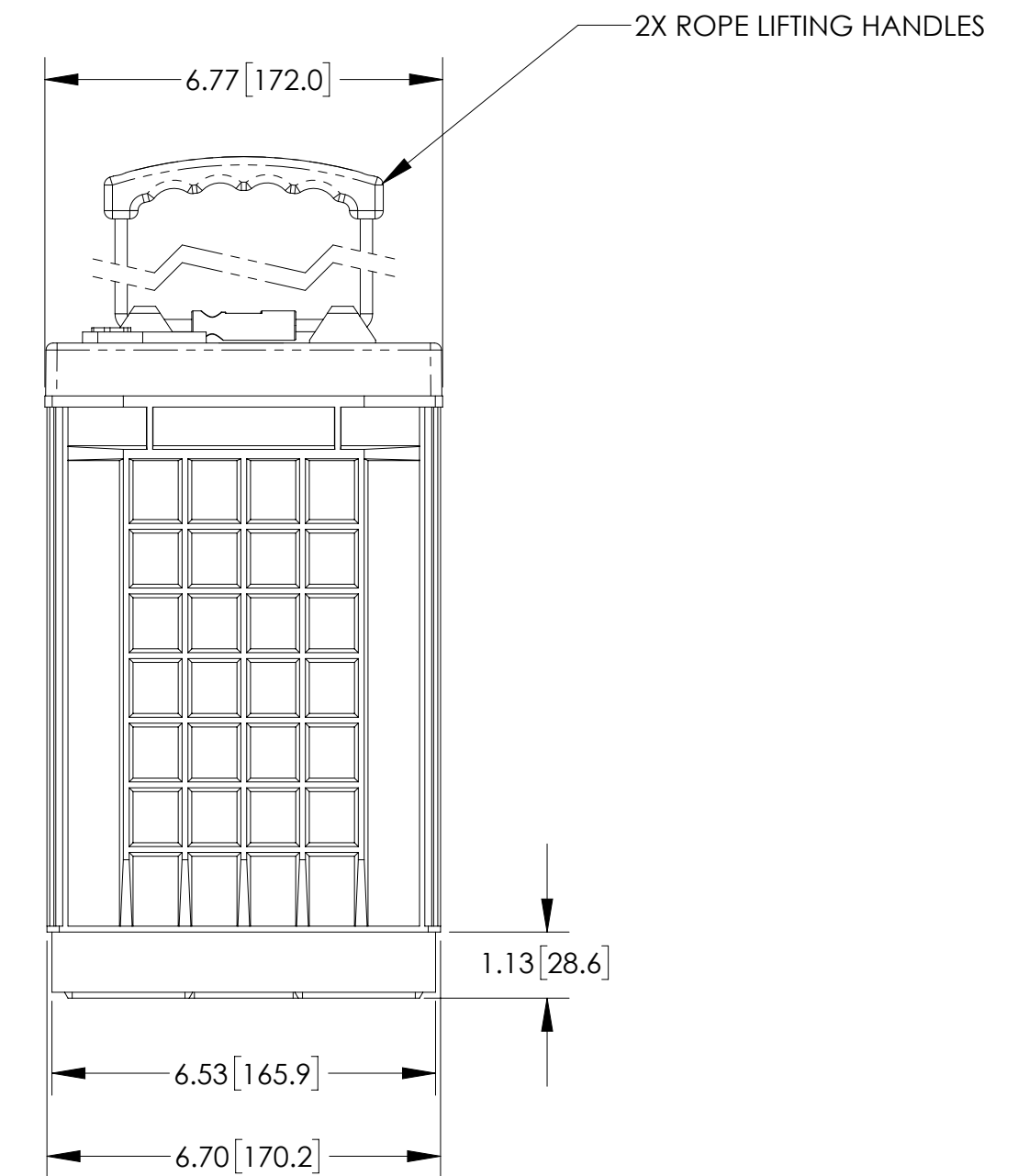
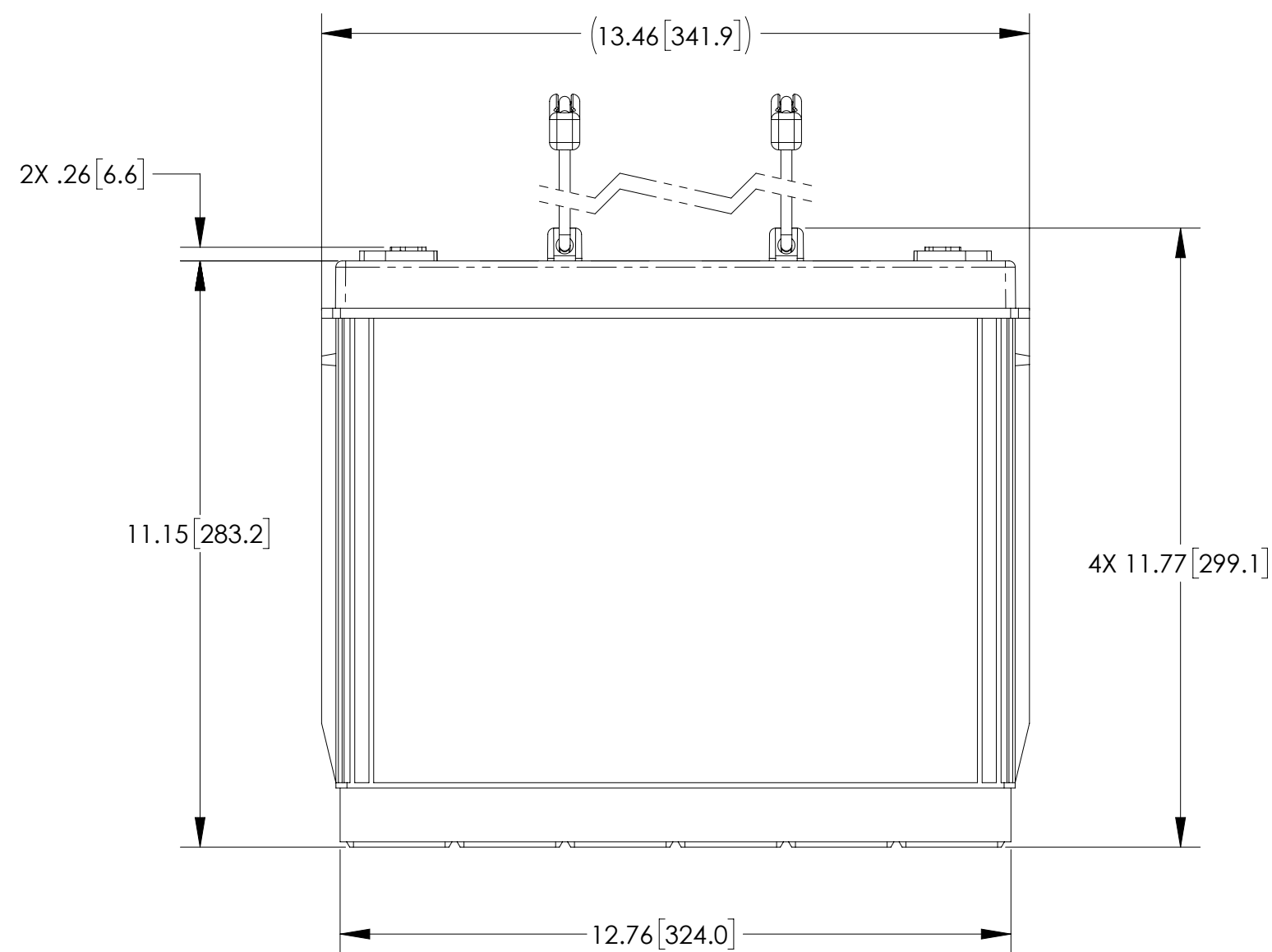

ENVELOPE DRAWING

CAPACITY RATINGS	
PART NUMBER	AGM-12148T
NOMINAL WEIGHT	90 LBS [40.8 KG]
AMPERE HOUR CAPACITY @ 20 HOUR 1.75 VOLTS/CELL @ 77°F (25°C)	150 AH
MINUTES OF DISCHARGE @ 25 AMPS 1.75 VOLTS/CELL @ 77°F (25°C)	315 MIN

UNLESS OTHERWISE SPECIFIED DIMENSIONS ARE IN INCHES TOLERANCES ARE:		CONTRACT NO.		CONCORDE BATTERY CORPORATION 2009 SAN BERNARDINO RD, W. COVINA, CA 91790				
FRACTIONS ±1/32	DECIMALS .XX ± .12 .XXX ± .060	ANGLES ±1°	APPROVALS	DATE	TITLE			
			DRAWN N.SANCHEZ	6/30/09	BATTERY, 12 VOLT, AGM-12148T			
TREATMENT	NONE	CHECKED	AMIII	7/13/09	SIZE	CAGE CODE	DWG NO.	REV
FINISH	NONE	APPROVED	JBT	7/14/09	C	63017	AGM-12148T	B
SIMILAR TO	CALC WT	ISSUED	JG	12/20/17	SCALE	1:3	SHEET	1 OF 1