

NOTES: UNLESS OTHERWISE SPECIFIED

1. SEE DRAWING NO. CB-00290 AND PROCEDURE P-1000 FOR ASSEMBLY AND TEST INSTRUCTION. PROCEDURES AND ASSEMBLY DRAWINGS ARE FOR INTERNAL USE ONLY.
2. ALL TESTING IS PERFORMED IAW BATTERY COUNCIL INTERNATIONAL STANDARDS.
3. ALL DIMENSIONS ARE INCH [MM]

REVISIONS			
REV	DESCRIPTION	DATE	APPROVED
A	REDESIGNED COVER	12/21/17	PH

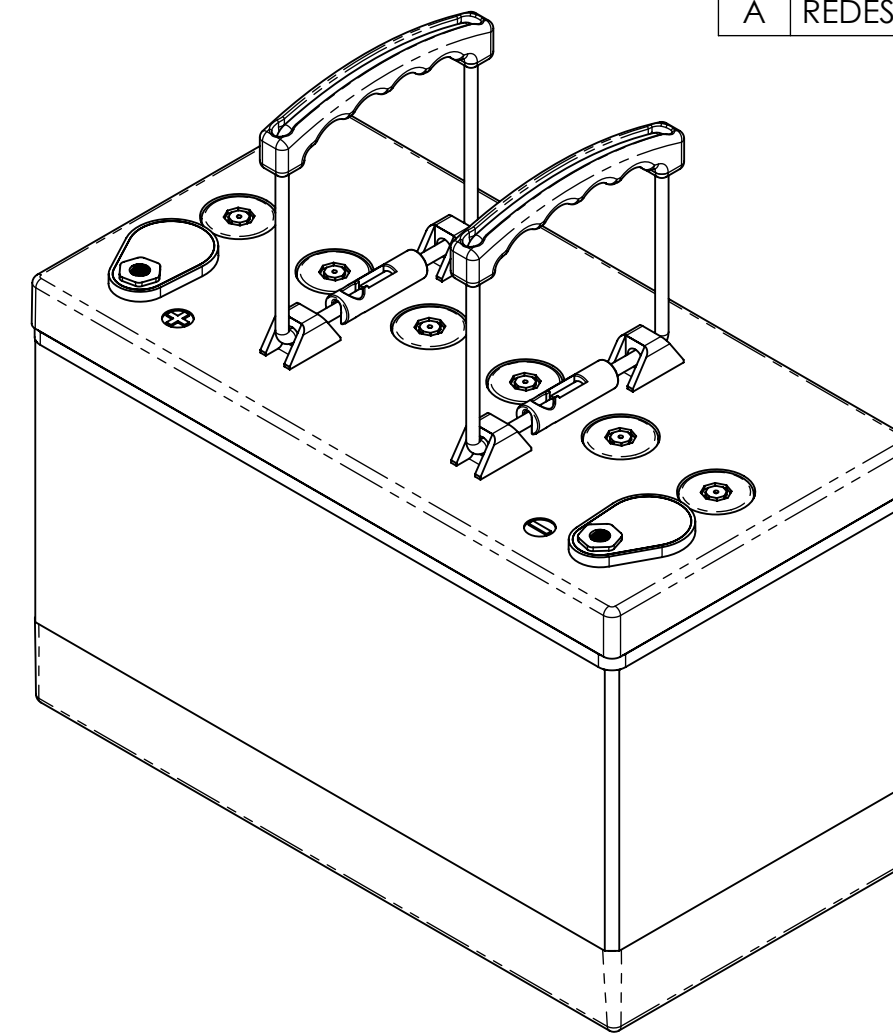

ISOMETRIC VIEW

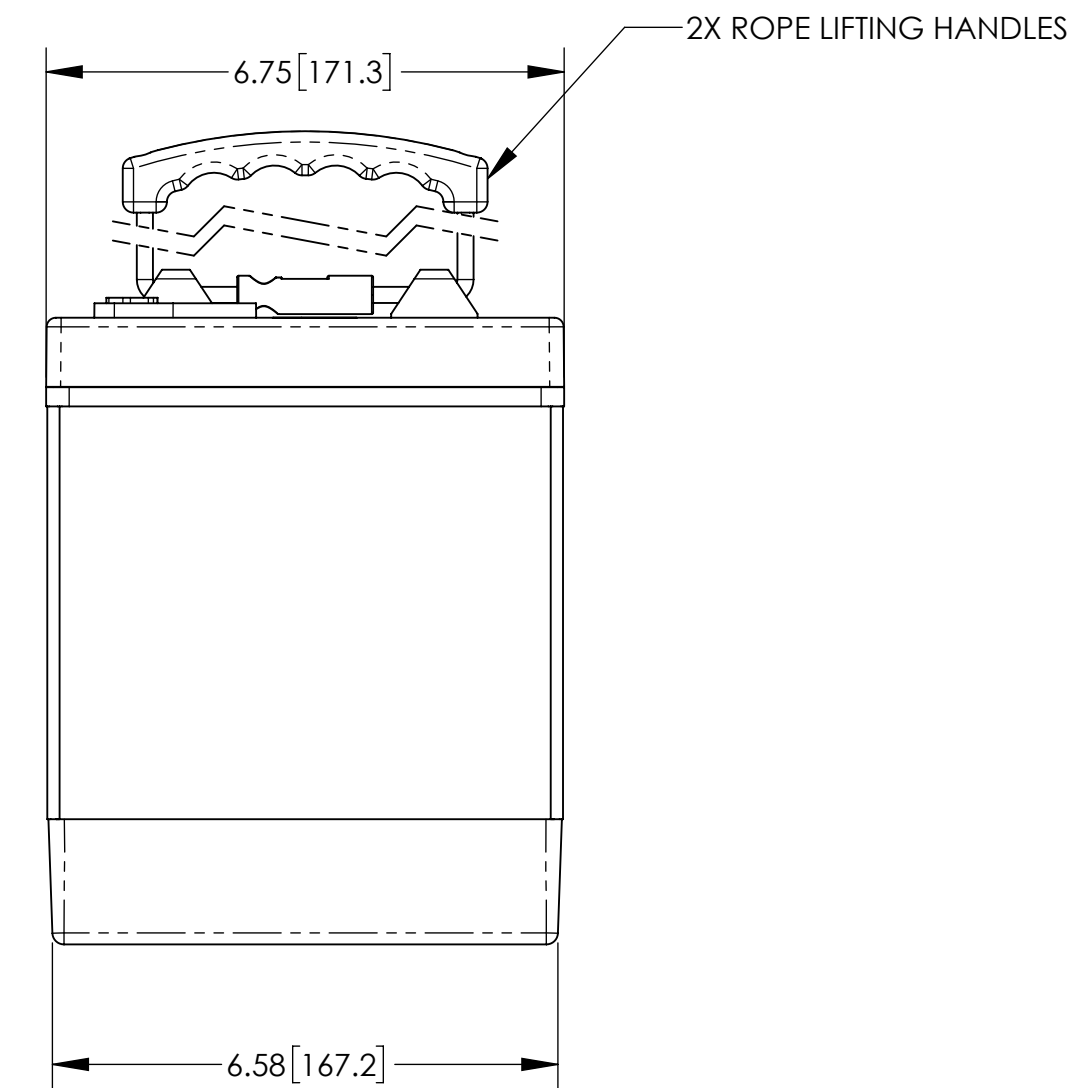
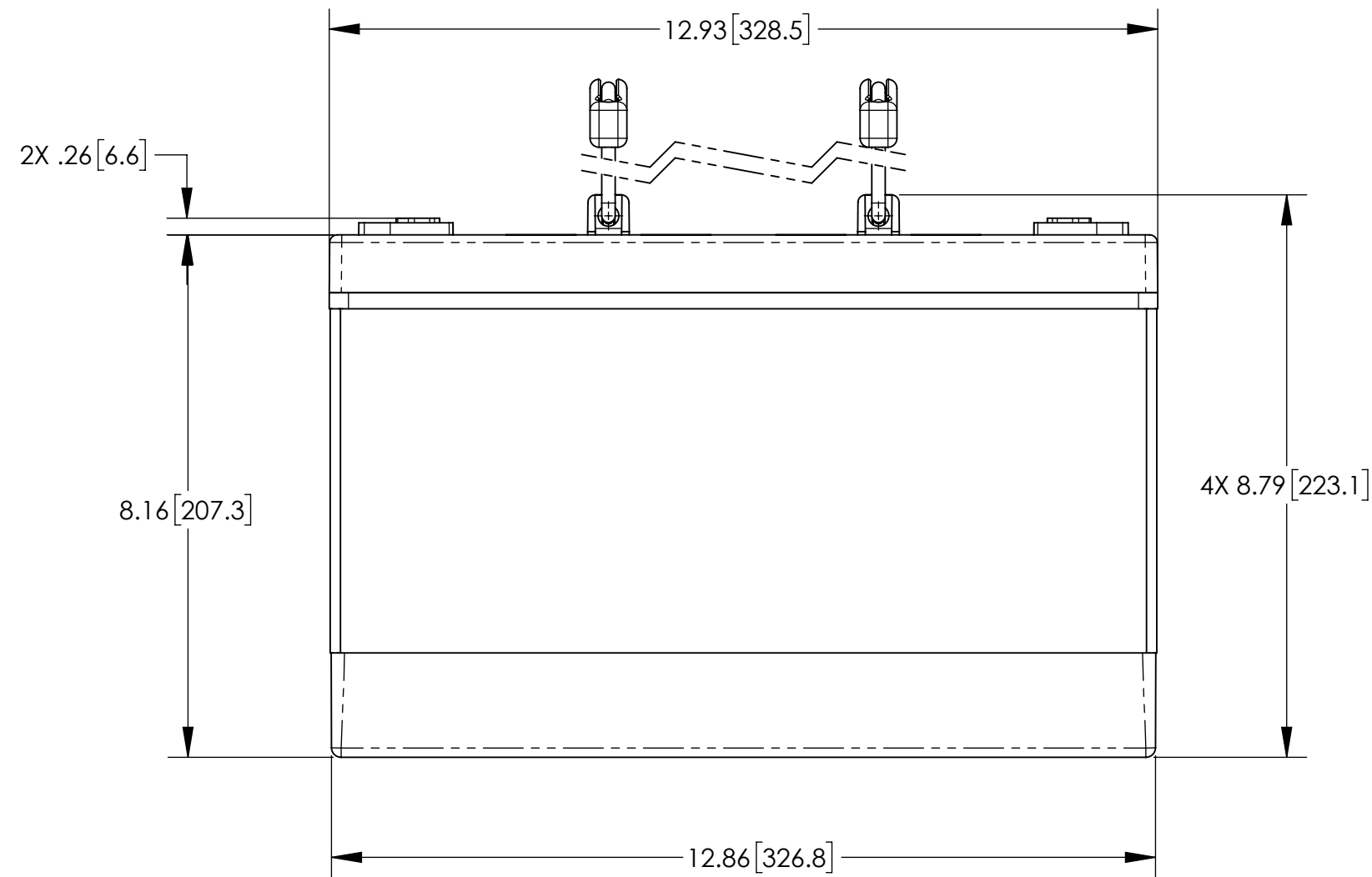
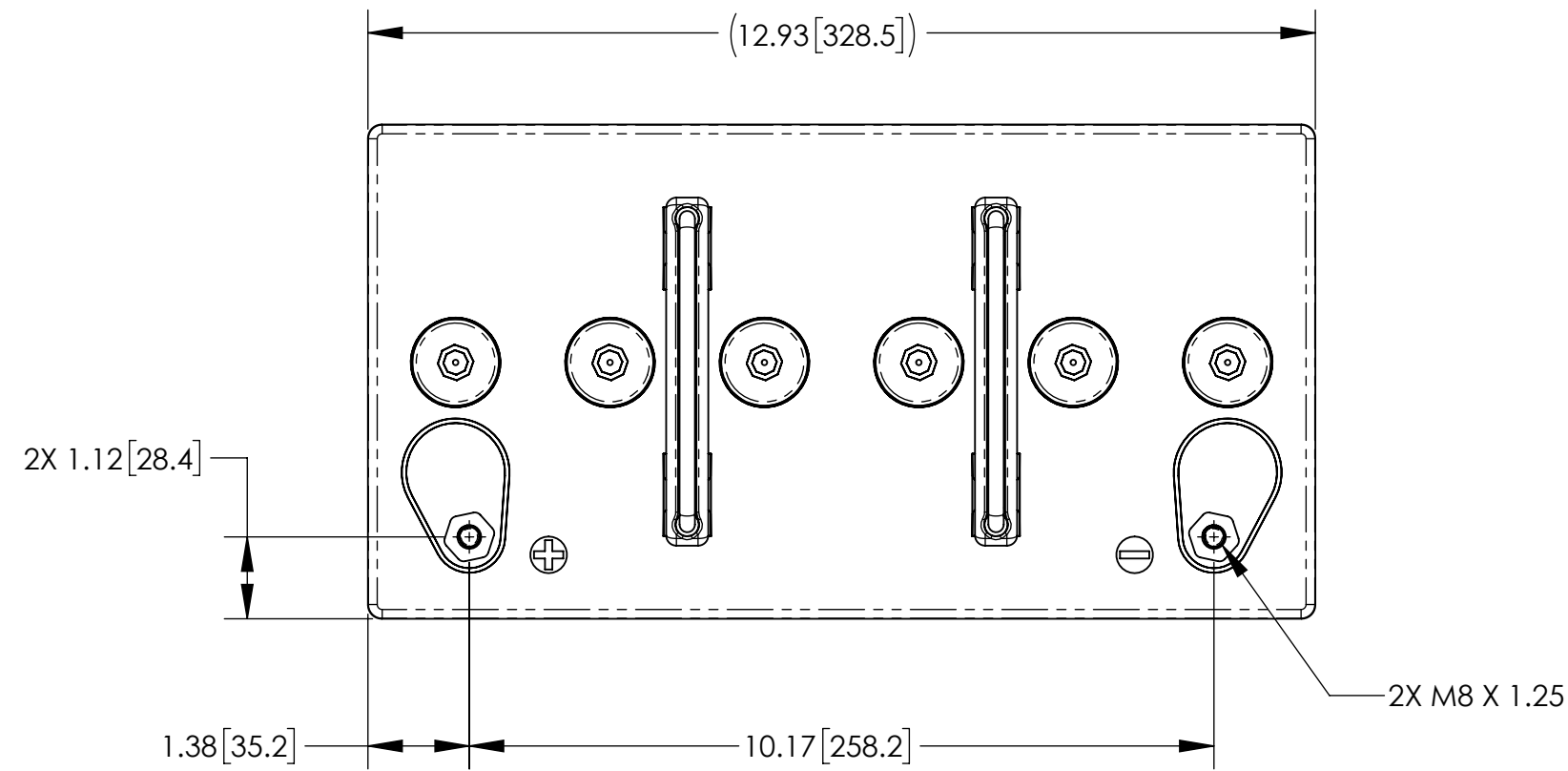

CAPACITY RATINGS	
PART NUMBER	AGM-12115T
NOMINAL WEIGHT	71 LBS [32.2 KG]
AMPERE HOUR CAPACITY @ 20 HOUR 1.75 VOLTS/CELL @ 77°F (25°C)	115 AH
MINUTES OF DISCHARGE @ 25 AMPS 1.75 VOLTS/CELL @ 77°F (25°C)	210 MIN

ENVELOPE DRAWING

UNLESS OTHERWISE SPECIFIED DIMENSIONS ARE IN INCHES TOLERANCES ARE:			CONTRACT NO.		CONCORDE BATTERY CORPORATION 2009 SAN BERNARDINO RD, W. COVINA, CA 91790				
FRACTIONS	DECIMALS	ANGLES	APPROVALS	DATE	TITLE				
±1/32	.XX ± .06 .XXX ± .060	±1°	DRAWN	D. AYALA	5/16/11	BATTERY, 12 VOLT, AGM-12115T			
TREATMENT	NONE		CHECKED	AMIII	5/17/11	SIZE	CAGE CODE	DWG NO.	REV
FINISH	NONE		APPROVED	DV	5/17/11	C	63017	AGM-12115T	A
SIMILAR TO	CALC WT		ISSUED	JG	12/22/17	SCALE	1:2.5		SHEET 1 OF 1