

NOTES: UNLESS OTHERWISE SPECIFIED

1. SEE DRAWING NO. CB-00290 AND PROCEDURE P-1000 FOR ASSEMBLY AND TEST INSTRUCTION. PROCEDURES AND ASSEMBLY DRAWINGS ARE FOR INTERNAL USE ONLY.
2. ALL TESTING IS PERFORMED IAW BATTERY COUNCIL INTERNATIONAL STANDARDS.
3. ALL DIMENSIONS ARE INCH [MM]

REVISIONS			
REV	DESCRIPTION	DATE	APPROVED
G	REDESIGNED COVER	12/21/17	PH

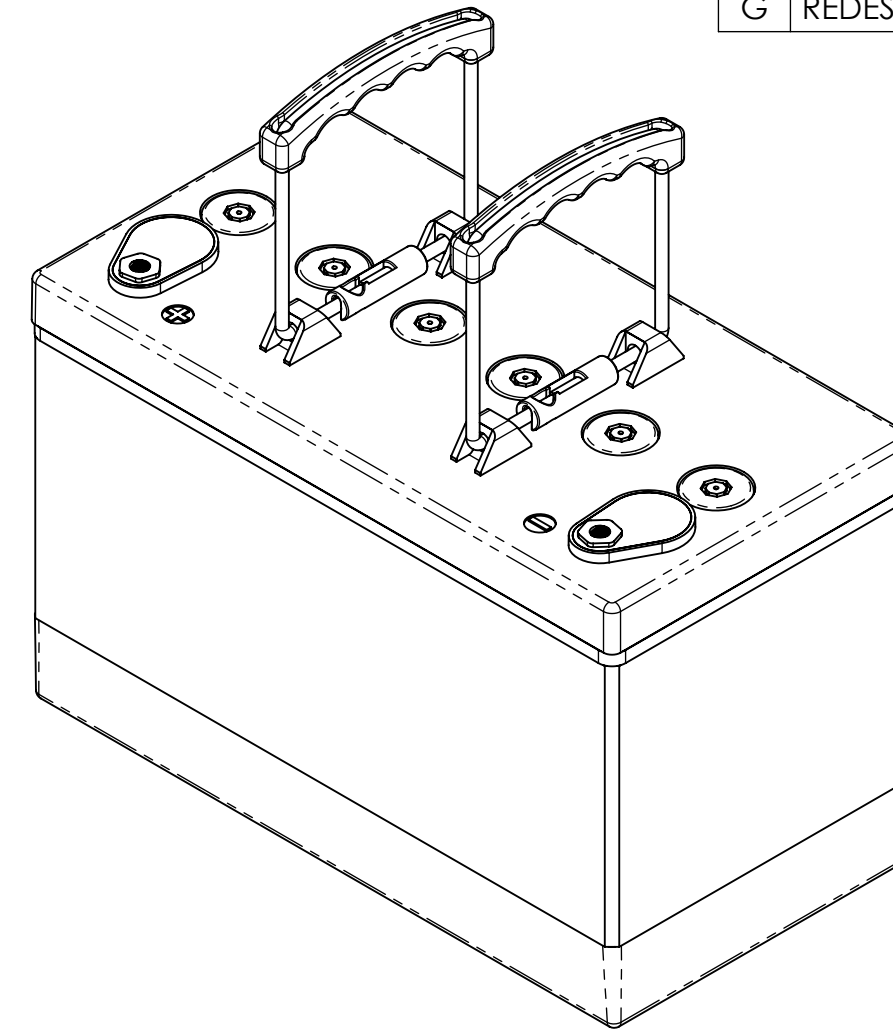

ISOMETRIC VIEW

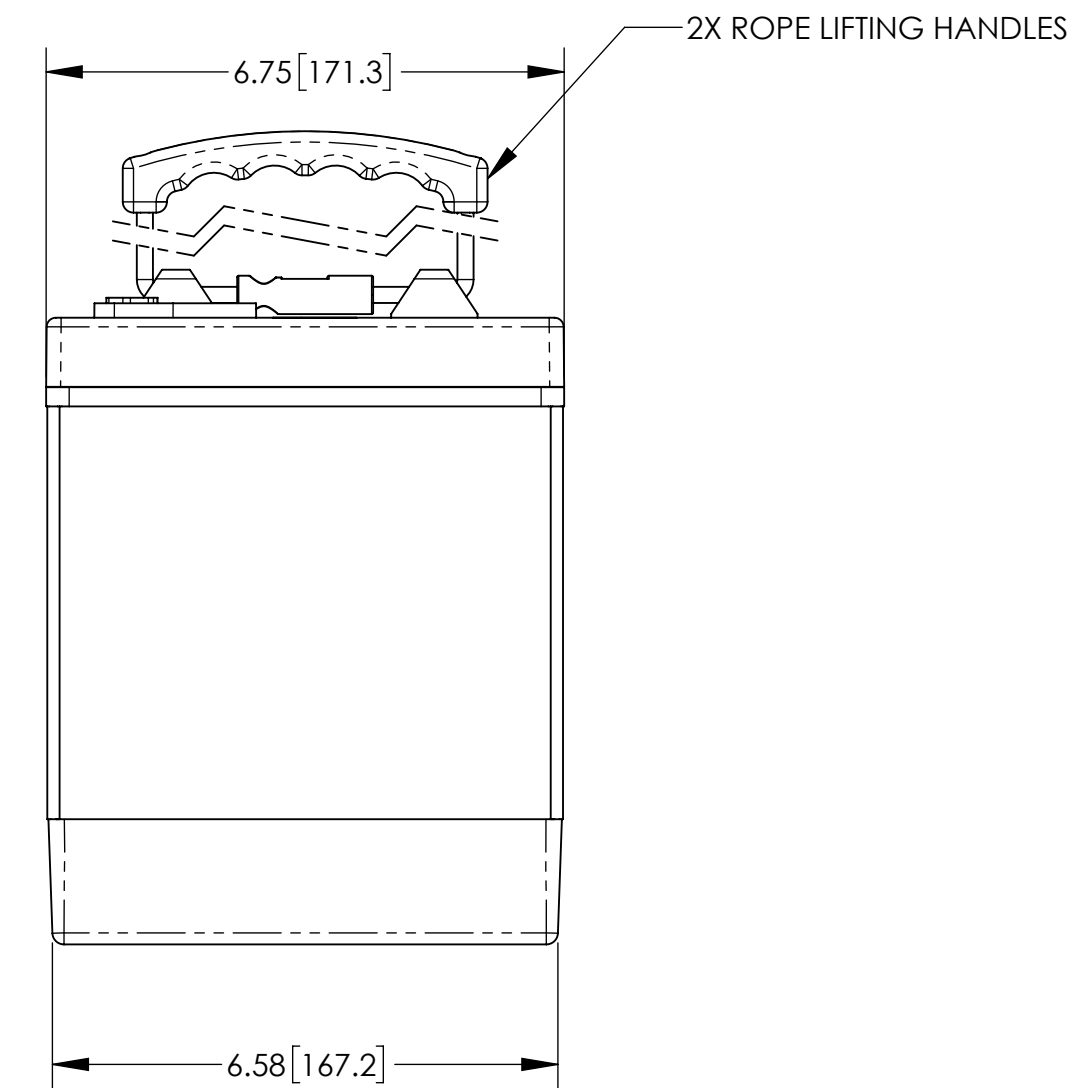
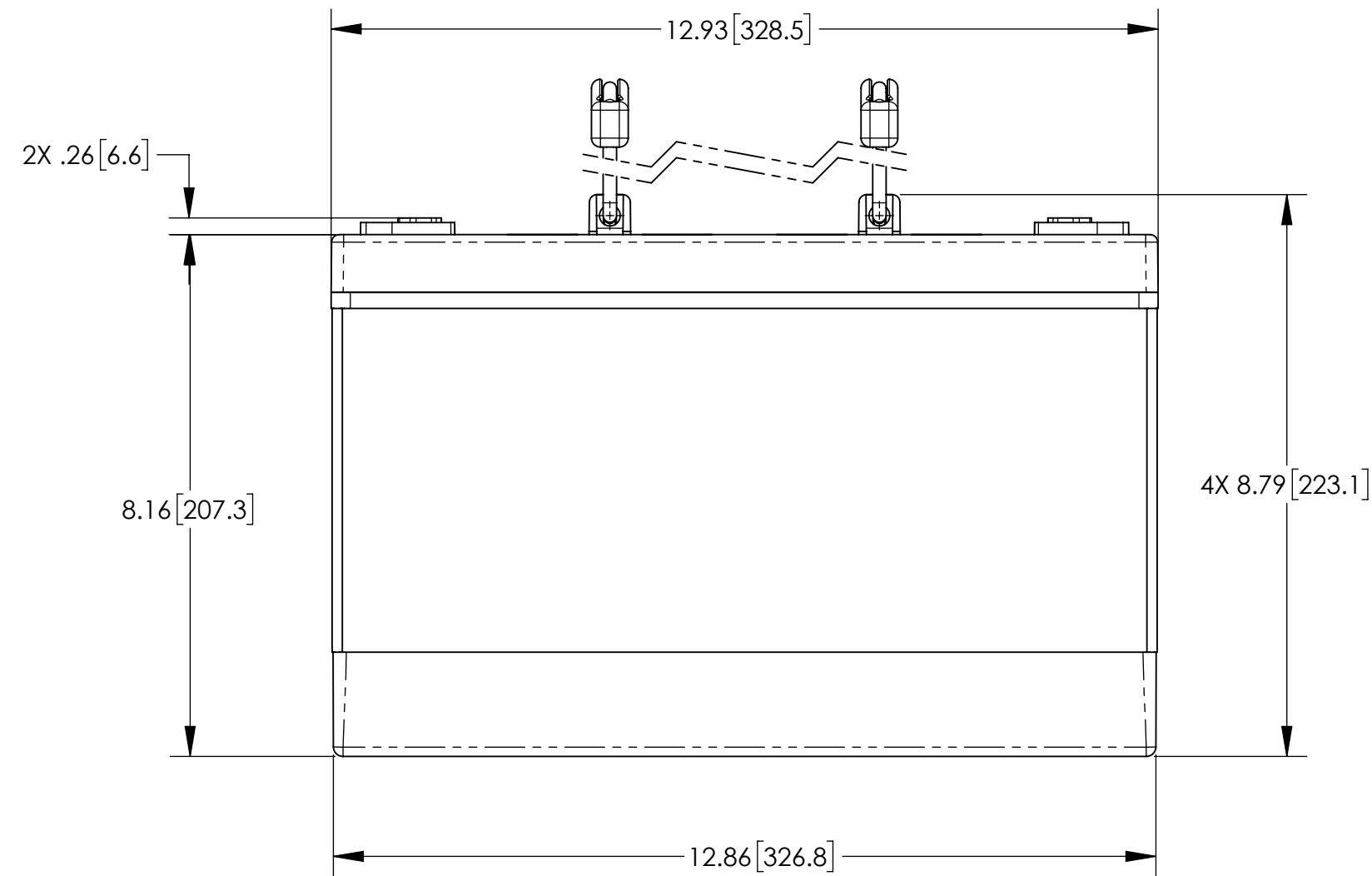
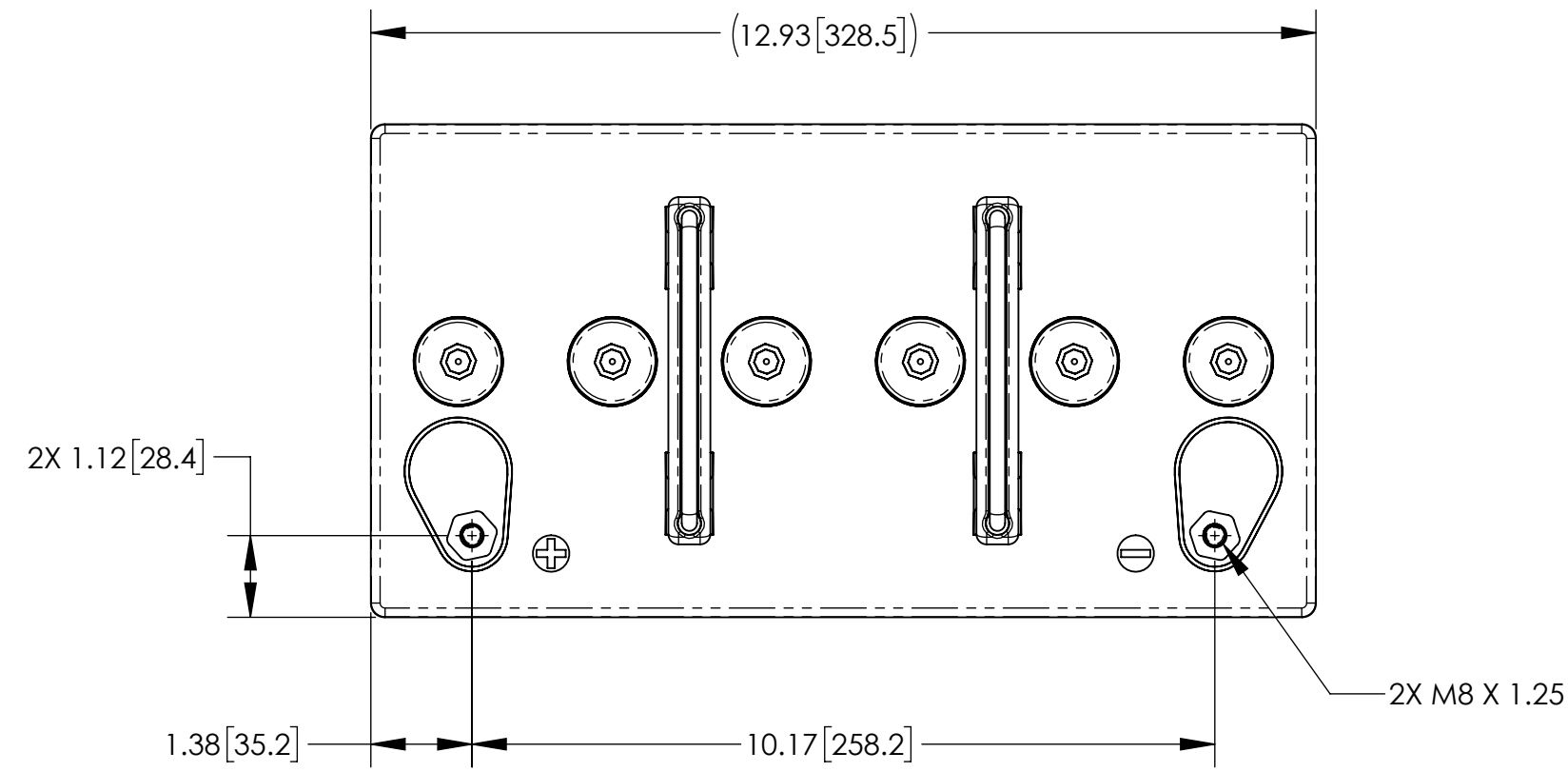

CAPACITY RATINGS		
PART NUMBER	AGM-1285T	AGM-12105T
NOMINAL WEIGHT	62 LBS [28.2 KG]	64 LBS [29 KG]
AMPERE HOUR CAPACITY @ 20 HOUR 1.75 VOLTS/CELL @ 77°F (25°C)	85 AH	105 AH
MINUTES OF DISCHARGE @ 25 AMPS 1.75 VOLTS/CELL @ 77°F (25°C)	158 MIN	195 MIN

ENVELOPE DRAWING

UNLESS OTHERWISE SPECIFIED DIMENSIONS ARE IN INCHES TOLERANCES ARE:			CONTRACT NO.		CONCORDE BATTERY CORPORATION 2009 SAN BERNARDINO RD, W. COVINA, CA 91790			
FRACTIONS ±1/32	DECIMALS .XX ± .06 .XXX ± .060	ANGLES ±1°	APPROVALS		DATE		TITLE	
			DRAWN	ELH	3/1/00		BATTERY, 12 VOLT, AGM-12105T SERIES	
TREATMENT			CHECKED	S. VALDEZ	3/1/00		SIZE	CAGE CODE
FINISH			APPROVED	JBT	3/4/00		C	63017
SIMILAR TO			ISSUED	JG	12/22/17		DWG NO.	REV
CALC WT						AGM-12105T		G
			SCALE			1:2.5		SHEET 1 OF 1