

NOTES: UNLESS OTHERWISE SPECIFIED

1. SEE DRAWING NO. CB-00285 AND PROCEDURE P-1000 FOR ASSEMBLY AND TEST INSTRUCTION. PROCEDURES AND ASSEMBLY DRAWINGS ARE FOR INTERNAL USE ONLY.
2. ALL TESTING IS PERFORMED IAW BATTERY COUNCIL INTERATIONAL STANDARDS.
3. ALL DIMENSIONS ARE INCH [MM].

REVISIONS			
REV	DESCRIPTION	DATE	APPROVED
D	SEE DCN AGM12100TD	8/10/11	JBT

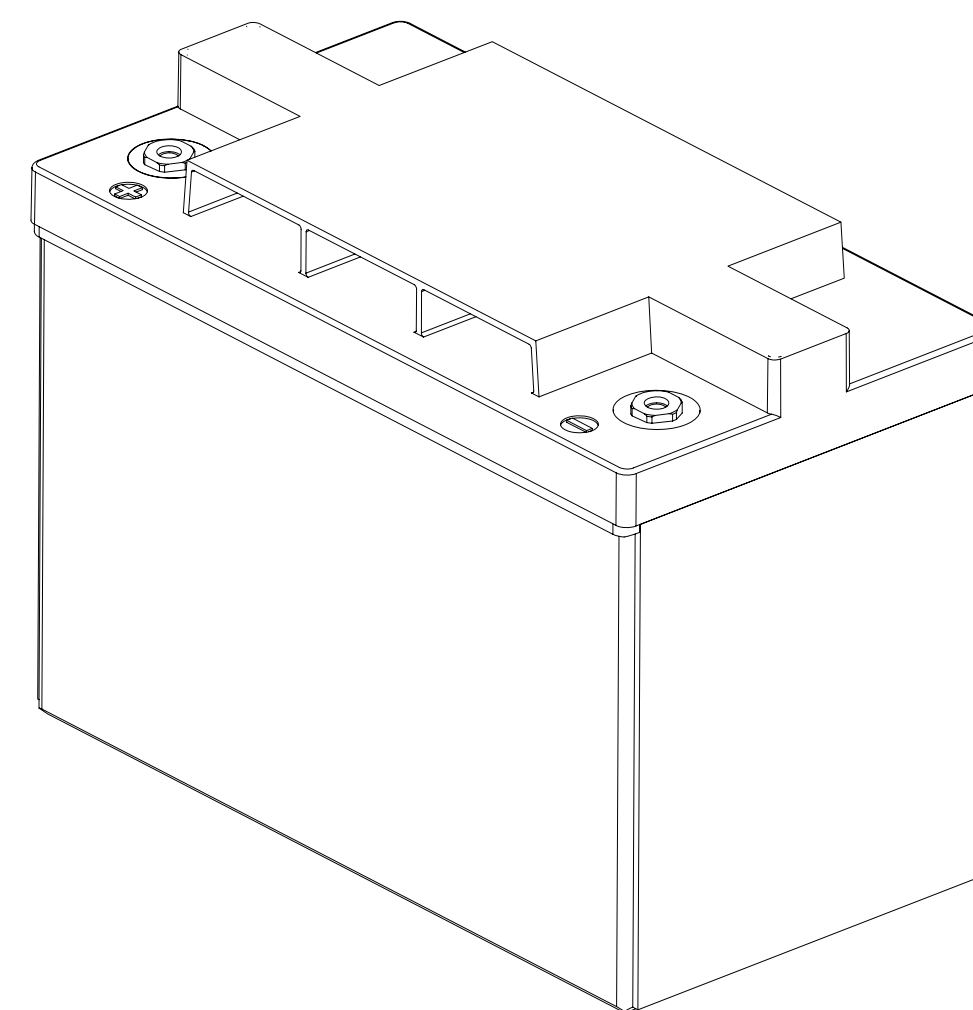
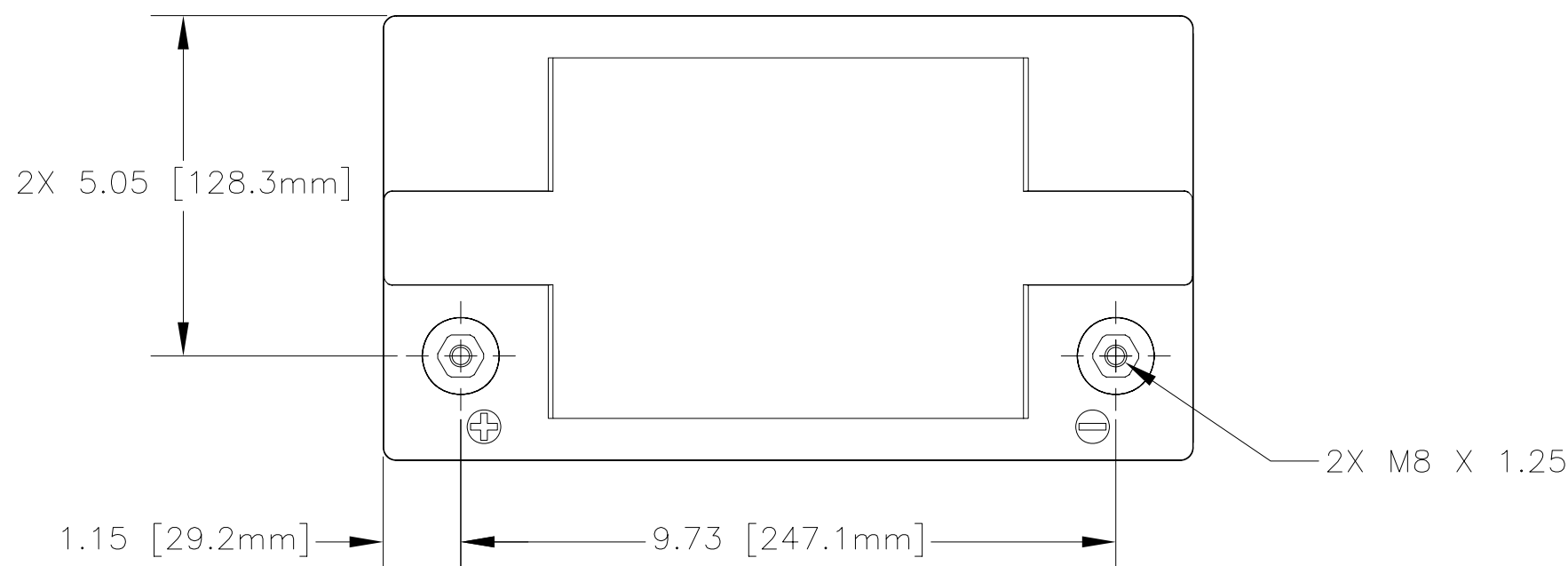

REFERENCE VIEW

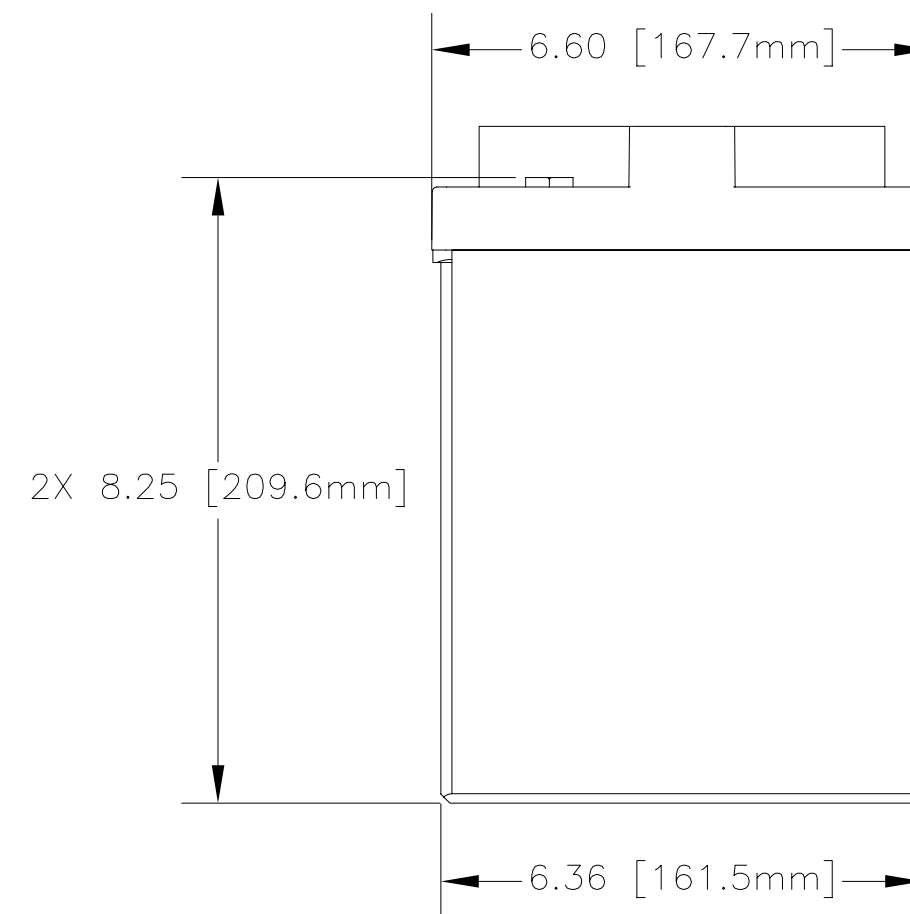
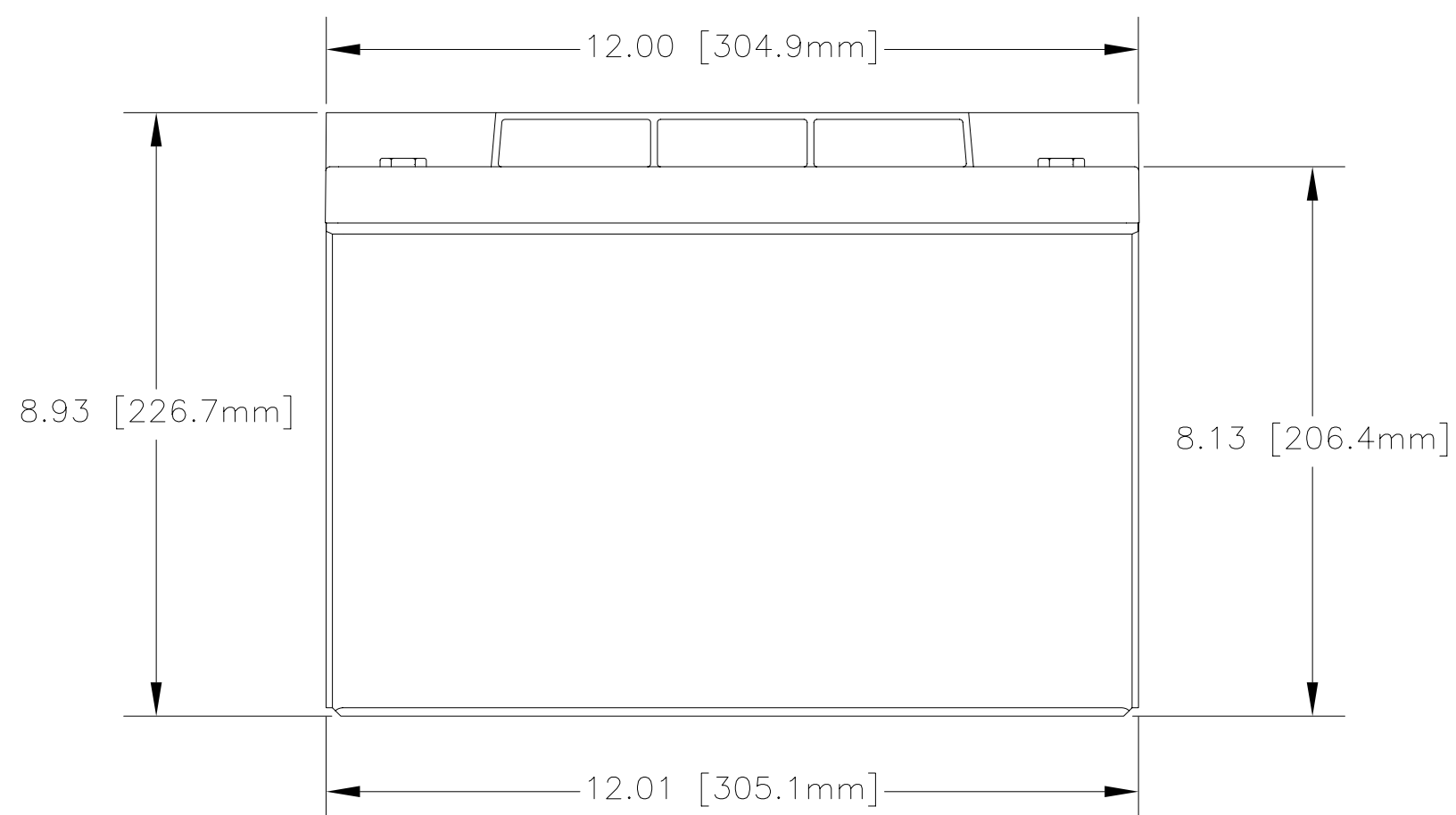

CAPACITY RATINGS	
PART NUMBER	AGM-12100T
NOMINAL WEIGHT	62 LBS [28.1 KG]
AMPERE HOUR CAPACITY @ 20 HOUR 1.75 VOLTS/CELL @ 77°F (25°C)	100 AH
MINUTES OF DISCHARGE @ 25 AMPS 1.75 VOLTS/CELL @ 77°F (25°C)	186 MIN

ENVELOPE DRAWING

QTY REQD	CAGE CODE	PART OR IDENTIFYING NO.	NOMENCLATURE OR DESCRIPTION	MATERIAL SPECIFICATION	ITEM NO.
PARTS LIST					
UNLESS OTHERWISE SPECIFIED DIMENSIONS ARE IN INCHES TOLERANCES ARE: FRACTIONS DECIMALS ANGLES ± 1/32 .XX ± .06 ± 1° .XXX ± .030			CONCORDE BATTERY CORPORATION 2009 SAN BERNARDINO RD, W. COVINA, CA 91790		
APPROVALS		DATE		TITLE	
DRAWN ELH		3/1/00		BATTERY, 12 VOLT, AGM-12100T	
CHECKED S.VALDEZ		3/1/00		SIZE	CAGE CODE
APPROVED JBT		3/4/00		C	63017
SIMILAR TO		ACT WT	CALC WT	DWG NO.	REV
				AGM-12100T	D
ISSUED JJ				8/12/11	SCALE NONE
				SHEET	1 OF 1